

Software Defined Radios

Lietuviškai

TinySDR for 80m band

My first look at the SDR technology was not very impressive - FlexRadio SDR-1000 was too complicated to build and too expensive to buy, but second one - SoftRock was another story: simple, clear principles and easy to build. I decided - SDR will be my next project. Several years ago I have made several direct conversions receivers and transceivers. Most of them were V. Poliakov RA3AAE designed, but also some from QST or other periodicals. I think radio amateurs paid not enough attention to this type of receivers until this time, SDR get them back.

My decision was to start from the very basic project included my tiny experience in direct conversion.

Schematics

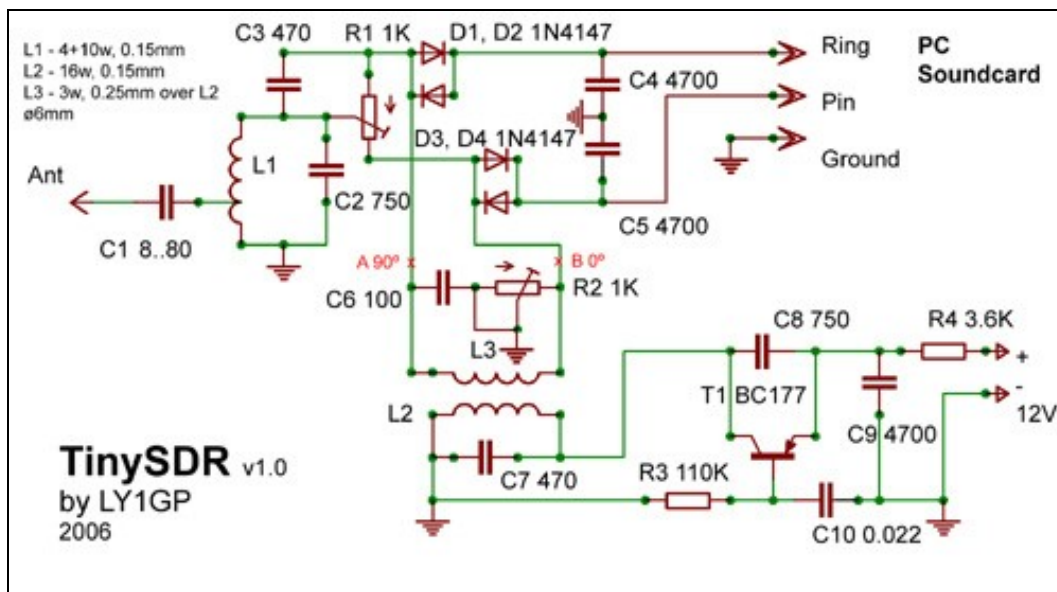

L1C2 - its the most simple band pass filter, tuned to the necessary frequency. To achieve better selectivity it would be better to have more complex band pass filter. There are many different variants on the internet to choose. It is interesting, that it is possible to make a receiver even without any band pass filter, but due to simplicity this not recommended.

Signal from antenna goes to double mixer (diodes D1-D4), at the same time signal from VFO is provided with different phases - 0 and 90 degrees. Just after mixer signal goes to PC soundboard. There are no low frequency amplifiers before PC plug. Audio amplification is done by PC soundboard, therefore it is recommended to use PC microphone jack, not Line-in.

VFO is made using the simplest circuit I can remember. Transistor T1 is of any type p-n-p one. Max working frequency is only important factor.

Materials

Diodes any type of 1N4147, 1N4148, 1N4154, also is it possible to use exUSSR made KD503, KD522, KD521. L1 has 4+10 turns of 0.15 mm copper wire (I used silk covered, but this not necessary), 4 from the ground. L2 - 16 turns of the

same wire, L3 3 turns of the 0.25 wire on the top of L2.

C1 value depends on the antenna used and can be selected for best performance. Also can be avoided totally.

Phase transformer values depends on the receiver frequency and should be calculated. Formula: $C6=1/(2*\pi*f*R)$, where f - VFO frequency, R - R2 resistor/2. Presented values are for 80 meter band.

Key point for the receiver performance is PC soundboard. Therefore soundcards recommended for the SDR-1000 (M-Audio Delta 44 and Delta 66) would be best performers, also several Creative products would be acceptable. But I used this receiver with several onboard audio chips (mainly AC'97), and they are OK. One of the main aspects is soundcard 16-bit or 24-bit, 16-bit allow to use 48 kHz range of band, 24-bit - 96 kHz - almost full old 40 meter band with same VFO setting.

Tuning

Some tuning is required. At the first with the help of oscilloscope tune your band pass filter, after with frequency counter - VFO for the selected frequency - this will be your band center. These are not critical you can tune receiver for highest sound and necessary ham radio station after second step.

Second step is to make phase transformer give necessary difference in phases. Connect twin input oscilloscope to points A and B, and choose the value of the R2 until you will have circle on the screen. Perfect circle means 90 degrees difference. I have read several times on the internet and in periodicals that it is impossible to make SDR based on analog devices, because 90 degrees difference with less than 1 degree can not be achieved. This could be true for high performance receivers (our is not such), and today we have software which can correct phase differences.

First working prototype:

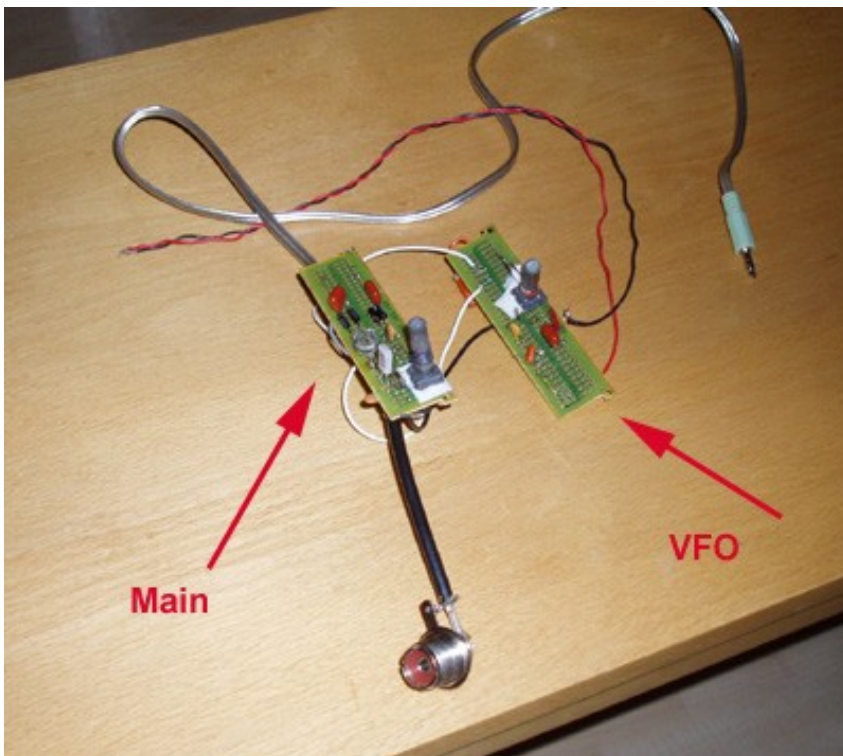

Couple of recordings (15m band dipole, industrial site):

ER1TA

UT5MD

I would recommend to select Rocky software due to compensating mechanism implemented or PowerSDR, which is used with SDR, but any other is OK also.

Rocky - in my opinion best balanced software.

PowerSDR - for SDR-1000.

ADDITIONS

IMPORTANT! For normal SDR reception with this receiver your PC should have stereo microphone input. This is not usual for todays modern PC's with AC'97 chipset, only few of them have such option. This option have most IBM ThinkPad notebooks, also some notebooks with Intel integrated sound, several Intel PC mainboards, also mainboards with SounMAX integrated sound. More advanced soundcards also provide stereo input. If your sound system do not have such option you will be able to receive, but you will have LSB+USB reception at the same time on both sides from VFO frequency.

Also it could be that line-in port is more sensitive to receive signals from this receiver, which is usually stereo. I will provide simple op-amp schematics to amplify signal and to use common line-in port.

2007.01.23 - to have maximum phase compensation - tune Rocky to strong station, keep this for a while and it will tunes itself for best option.

2007.01.25 - To keep receiver as simple as possible I have tested different VFO. If you have old PC mainboards, there could be clock oscillator for 14.318 MHz, which allow you to make VFO for 20 meter band.

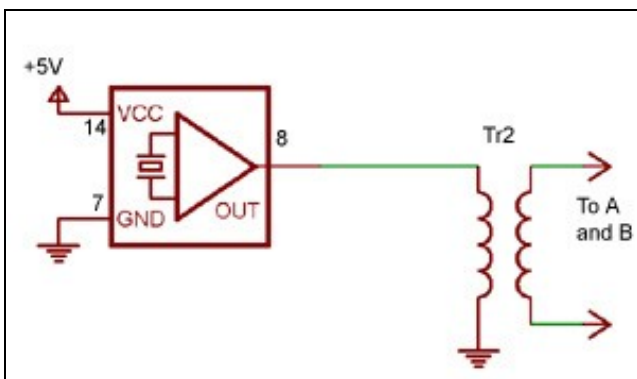

Tr2 - 10 turns primary with 0.25 wire and 2-3 secondary one. Oscillator any type and company. Just frequency is important.

ZetaSDR for 40m band

This receiver is more sophisticated, but I tried to keep it also simple as possible. I am actually not the author of the construction, I have seen such (or very similar) schematics on the internet, but can not find it again. Anyway, its also simple way to get SDR in action.

Main mixer is made using 74HC4052. YU1LM is not very satisfied about this chip, because of unstability in higher frequencies. I have not tested in full HF range, but for 7 Mhz it is fully functional. *No winding here! :)*

Finished construction



[Schematics \(click to get full size\):](#)

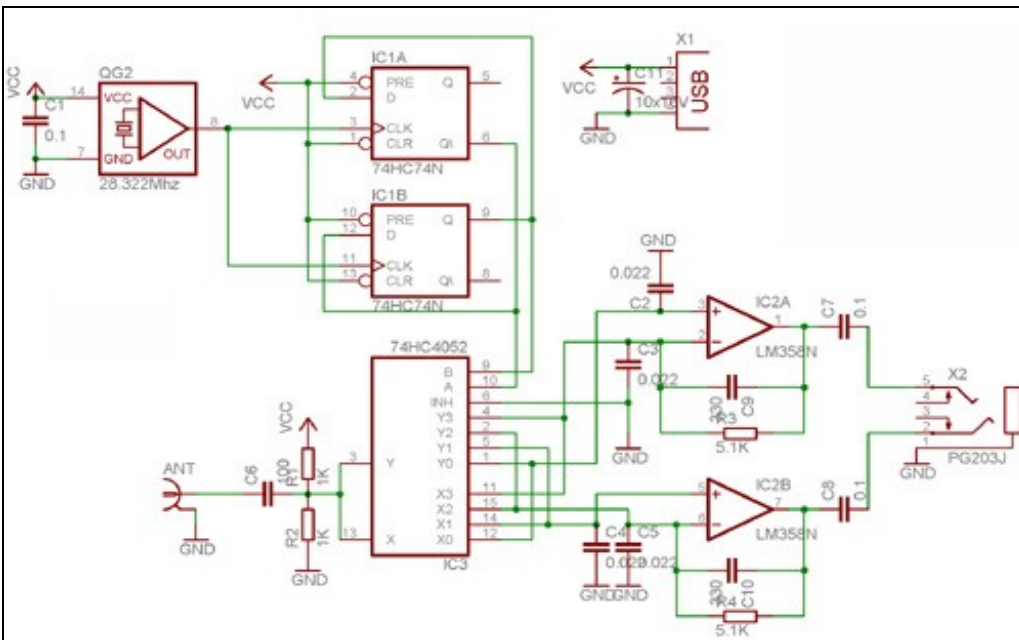

[PCB and partslist here.](#)

PCB size 50 x 66 mm, one sided. Do not forget one unrouted wire.

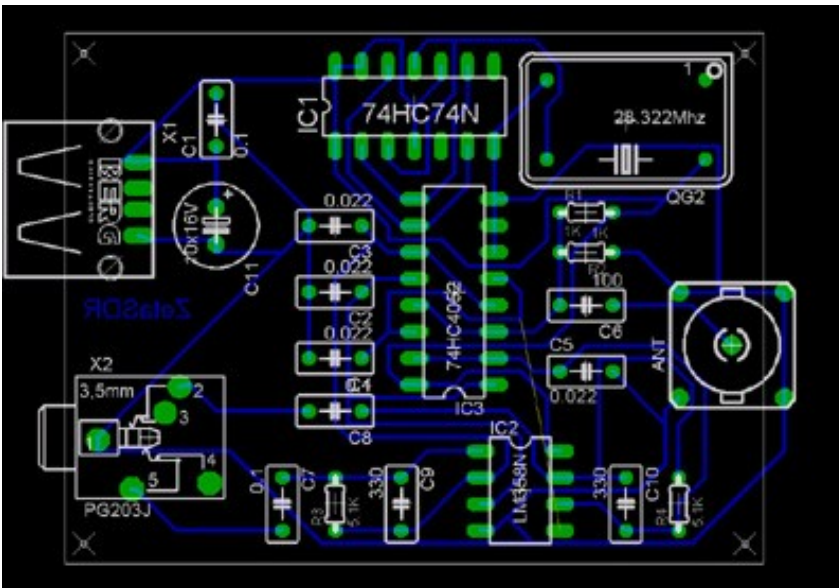

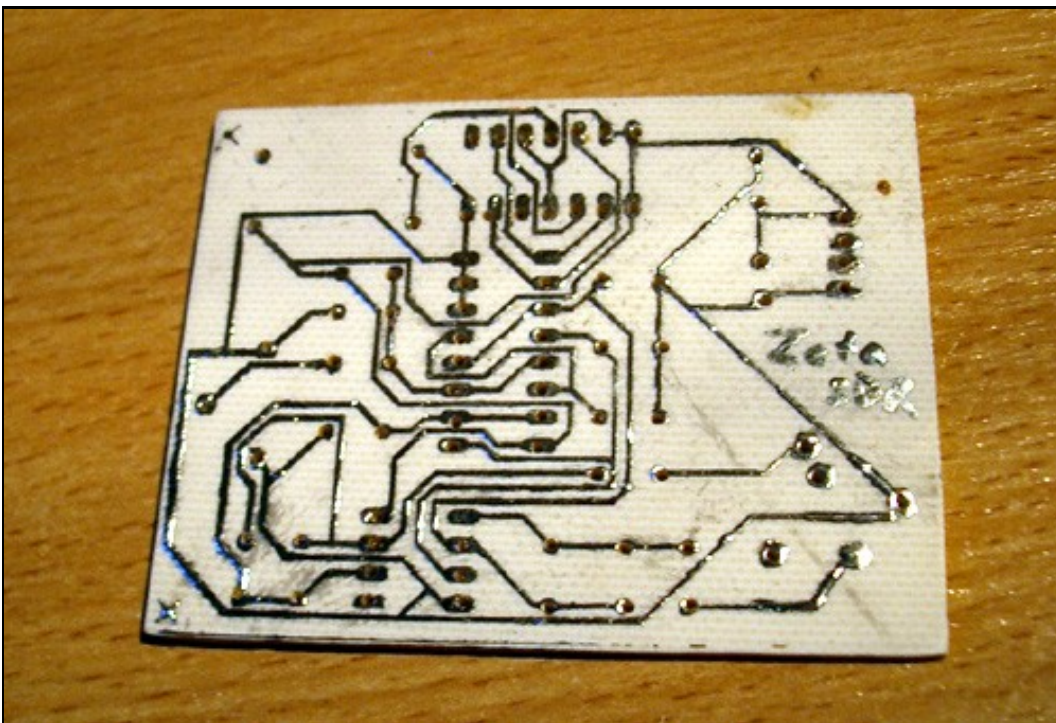
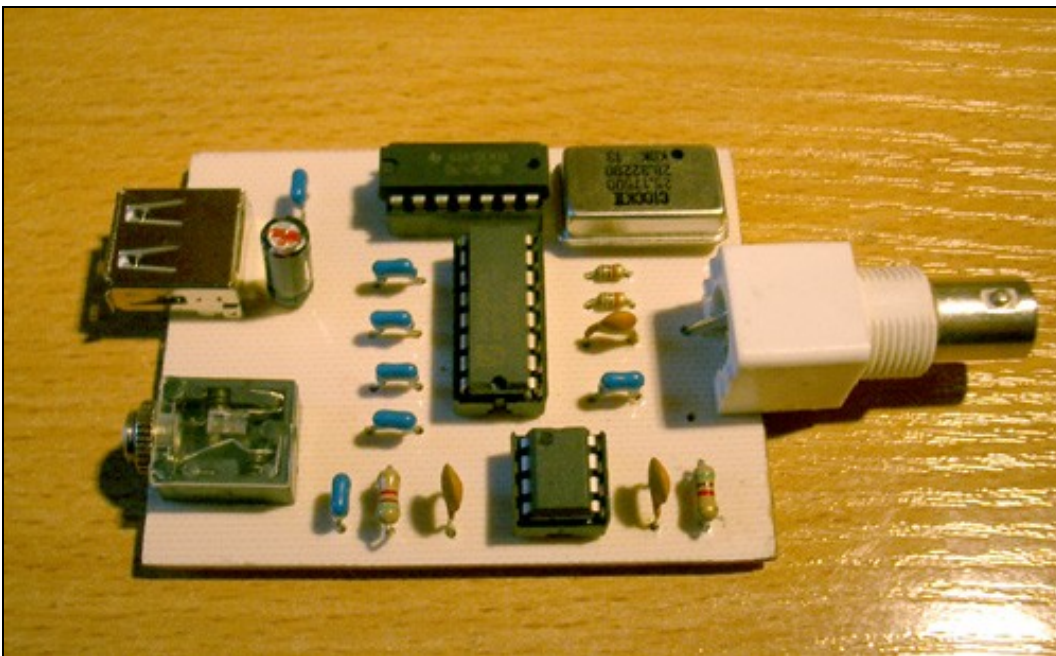

If no errors made - connect and enjoy.

Several RX examples (made just on occasion, antenna - W3DZZ multiband, AC'97 integrated sound):

- 9K2RA
- IW0RZY
- HG3A
- HA1YI

ADDITIONS

2007.02.02 - Tasiã YU1LM reported that 74HC4052 is good up to 10 Mhz. Using it on higher frequencies result to worse image rejection.

2007.03.15 - I will try to answer to several questions regarding this construction, which I was asked several times:

- Capacitors values in schematics are - in microfarads (uF) if number is with dot, like 0.022 is 0.022 uF (or same 22nF), others are in picofarads (pF) like 330 means 330 pF.
- Clock oscillator frequency is not critical - you can choose any available oscillator which frequency divided by 4 goes into ham bands range. Instead of my used very often 14.318 oscillator could be found, which let you listen 80 m band ($14.318/4=3.5798$). These oscillators generally could be found in old mainboards, video cards, even hard drives.
- I am frequently asked about the possibility to sell kits of this construction. In certain cases I can do that - kits will be without clock oscillator, and BNC connector and there is a problem with PCB - until this moment I made them at home which is not suitable for kit business, but if there will be many requests I will found a solution. In any case contact me concerning this.
- I already started simple DDS project for this receiver to make it multiband.

2007.08.28 - My ZetaSDR now on the net: <http://88.119.248.188:8000>. You can listen it on Winamp. The only problem is that there is no software on the market to control such SDR hardware, therefore it is locked to around 7.075 Mhz.

Gintaras LY1GP, ly1gp{ @ }qrz.lt