

Renaissance of HF DC (Direct Conversion) receivers Part1

Dipl ing. Tasić Siniša-Tasa YU1LM/QRP

First receiver I was ever built for HF was tube receiver without RF amplification called OV2 .It was working good and enable me to listen short waves and HAM bands. After that I build super heterodyne receivers but when I built DC transceiver by W7EL at the beginning of 80's ZL2BKW version I was surprised how good DC receiver can be. With simple dipole antenna for 7MHz I worked 102 DXCC in 1985/86 with not to often work and with output power 1W (BD135 output transistor). After that I made a lot of HF and VHF DC receivers HAM and for professional use, my or other authors design. In year 2000 I made presentation in KKE club Belgrade with next subject "**Renaissance of HF DC receivers**". Paper material contains 30 pages collected materials about DC receivers with schematics, useful formulas for calculation, PCBs and complete receivers made or design by author. I received in last time over 40 request for the translation original article. This is translation of original article from year 2000. Now in 2007 I have quite different point of view to the some subject and because of that I am preparing new article part 2 with direct receivers designed and tested by author. I apologize that this materials schematics and comments on them are still written on Serbian language Subject DC (direct conversion) receivers in next text DC is not often subject in amateur and professional articles and we can hard find some original designs and realizations. The older homebrew can remembered with an nostalgia DC receivers called OV1, .. or similar types .In late 60th, 70th this was the easiest way to receive HF broadcast and amateur bands. These types of receivers have relative good sensitivity. Super-regenerative process is used for the demodulation SSB/CW signals. The situation on HF bands now is quite different that it was at that time. HF bands are now crowded with enormous big number strong signals. The DR (dynamic range) this kind of receivers is very poor and receivers are producing a lot of IMD and non existing signals in the air. Because of that this kind of receivers which still have big use specially in simple alarm, remote control receivers I will not take in consideration. In this article I shall describe receivers with next block diagram pic1. These receivers have separated LO (local oscillator called VFO or BFO) and they can be divided in 3 main categories:

1. DC receivers without image rejection

2. DC receivers with image rejection

3. DC receivers with image rejection according to the third method called DC RX Weaver type.

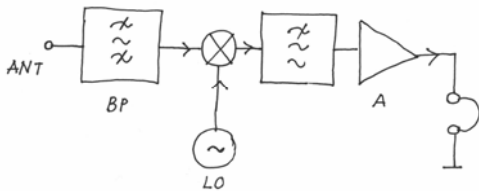

Pic1. DC RX block diagram

Before we start with DC subject I shall make short comparison between DC (direct conversion) and super-heterodyne RX-s.

The super-heterodyne receivers are:

- complicate with their block diagram structure and extremely complicate for adjustment. Generally they are very expensive (big number different IF filters, mixers...etc)
- they have problems with image frequency ($F_{in} \pm IF$), with IF(intermediate frequency) choice and with choice mixing plan.
- they have problems with frequency synthesis (multiple PLL loops and phase noise).
- The main problems in super-heterodyne RX homebrew are related to the RF problems, but not only to them.
- The biggest advantage of this kind of receiver is that with careful design and proper component choice we can obtain very good performances. This results aren't accessible for the most homebrew amateurs reasons are components accessibility, their price, instruments for measuring and RF and other different kind of experience in receiver design area such as (DSP, computer)

DC receivers are from the other side:

-generally speaking substantially they are cheaper and simpler. This statement is true especially for the DC receiver in categorization number 1.

-they haven't problems with mixing, phase noise as super-heterodyne receivers have.

-very big image rejection is hard to achieve as it is possible with super-heterodyne receivers with IF filters.

-DC receivers are very sensitive to the strong broadcast AM (amplitude modulation) signals. In the case of DC receiver for 7 MHz we can hear unwanted music in the background which is hard to eliminate.

-high performance DC receiver isn't simple and cheap. It is very hard to design a good DC receiver for several HF bands.

-the biggest DC receiver advantage for homebrew is that they need modest RF experience and ordinary instruments like DMM (better digital multi-meter, perhaps RF generator or oscilloscope) are.

- My personal experience and not only mine in DC receiver listening is that they are real HI-FI (high fidelity) music compared to the most commercial super-heterodyne RX-s.

In order to find better understanding of DC subject modulation and demodulation process and reason for the phase shifting I draw picture pic2. At the pic2 is done vector, oscilloscope and spectrum analyzer screen shoots for modulations such as AM/CW/SSB/DSB and way for the modulation and demodulation process. These pictures do not take care to complicate mathematical explanation of Hilbert transformations with positive and negative frequencies which is hard to understand for the most people even for the people which have telecommunication as a professional job.

My initial idea for this article was to offer homebrew builders different solutions separate functional blocks which will enable experimenting in the DC receiver field with different design solutions. This experimenting way enables testing and checking advantages and disadvantages starting from components which every individual homebrewer has. Experimenting with different solutions will enable homebrewers to have experience to make some new DC receiver or even transceiver for CW/SSB. I have to apologize for mistakes and inconvenience for them for all who start with my schematics. The author has tested the most of schematics but not all. Analyses done in different CAD-s show that some authors wilfully and non-wilfully gave wrong component values or that they are errors during the printing process. I tried to correct all errors which I find. The design and realization of LO (VFO or BFO) the author didn't consider in this article. Also input band pass BP filters aren't taken into consideration and I proposed some relatively simple and easy solution for practical BP realization.

DC receivers as I told at the beginning are simple constructions but they have some problems in design and realization about which we have to take care. This was very exactly counted and explained by N.Hamilton G4TXG in magazine Radio Communication 4/1991:

RF hum phenomenon, AC from power supply with 50 Hz is modulating LO (local oscillator). The side band component from 50 Hz we are hearing as hum. The 50Hz is retransmitted from power supply lines and then received by RX antenna. This problem was described in ARRL handbook exactly. The solution for this problem is to screen LO or BFO in a closed box. The simplest solution is a box from soldered PCBs pieces which is the easiest way for preparing and soldering.

The AM detection phenomenon which I told that is typical for DC receivers. This phenomenon is happening in mixers because of their insufficient mixers (detector) linearity that they are working as AM detectors. Demodulated signal is then amplified by AF part of DC receiver. This phenomenon is happening also in super-heterodyne receivers but it is easy to eliminate with IF crystal filter. This phenomenon leads to a solution with sufficient selectivity in front of mixer (demodulator). The selectivity will decrease numbers and power of unwanted, out-band signals. Switching mixers like 74HC4066, 74CBT3253 ... will also decrease AM demodulation sensitivity substantially. Digital mixers enable us that we can directly connect antenna to the mixer input without input filters. Imagine this test with any other mixer types like DBM (diode mixers). Mixer's performance AM sensitivity is described with signal in mV at mixer input which will produce unwanted signal at noise level (MDS). Good values for mixers are 5-10mV or signals S9 plus 50-60 dB at mixer input. Solution for this problem is utility of better linearity mixer. The diode mixers with anti-parallel diodes which have LO at 1/2 fs and they have the best AM rejection performances from all diode mixers but I didn't consider this mixer type reason is other than their unwanted performances.

The AF hum effect is that AC 50 Hz directly in AF part of DC receiver. Gain distribution is quite different for the DC receivers than it is for super-heterodyne receivers. 100 dB of AF gain is quite normal situation for the DC receiver realization. The solution for this situation is RX PCB screening and utility of coax cables for connections.

The microphonic effect is AF or RF origin. The AF microphonic effect can be solved with good mechanical RX construction with rubber spacers. RF microphonic effect is caused by leakage LO to the mixer (demodulator) input. The signal is then reflecting from input BP, mechanical change or mechanical shock are changing phase reflected signals. The result is AF signal or DC signal which is unbalancing mixer. The solution for this effect is utility of high quality built-in components, or use moulded coils especially in the diplexer, filter circuit.

1. AM MODULACIJA

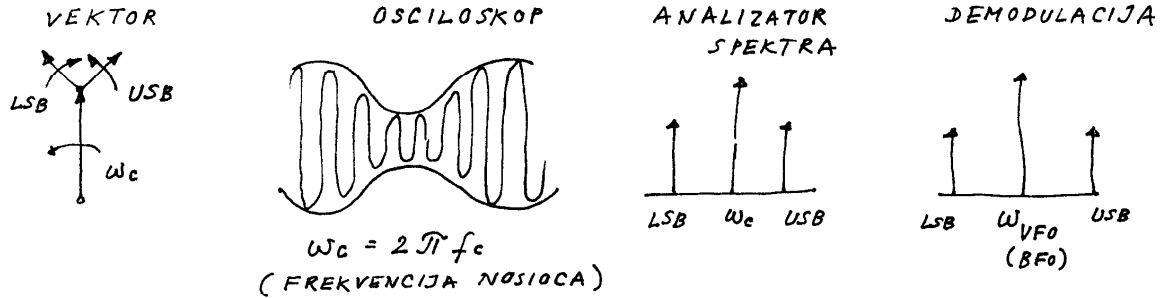

2. CW ILI SSB MODULACIJA SA JEDNIM TEST TONOM

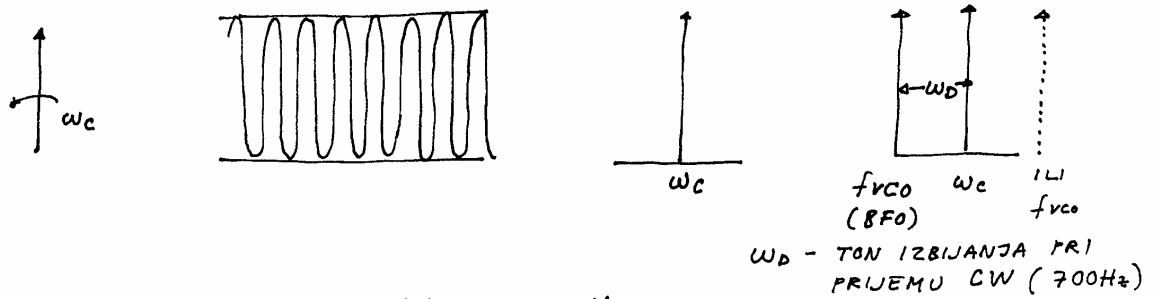

3. DSB MODULACIJA SA JEDNIM TONOM

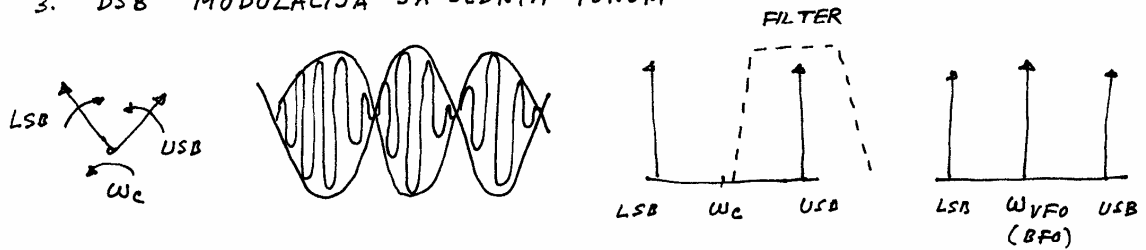

DEMODULACIJA DSB SIGNALA SA POTISKIVANJEM JEDNOG BOČNOG OPSEGA

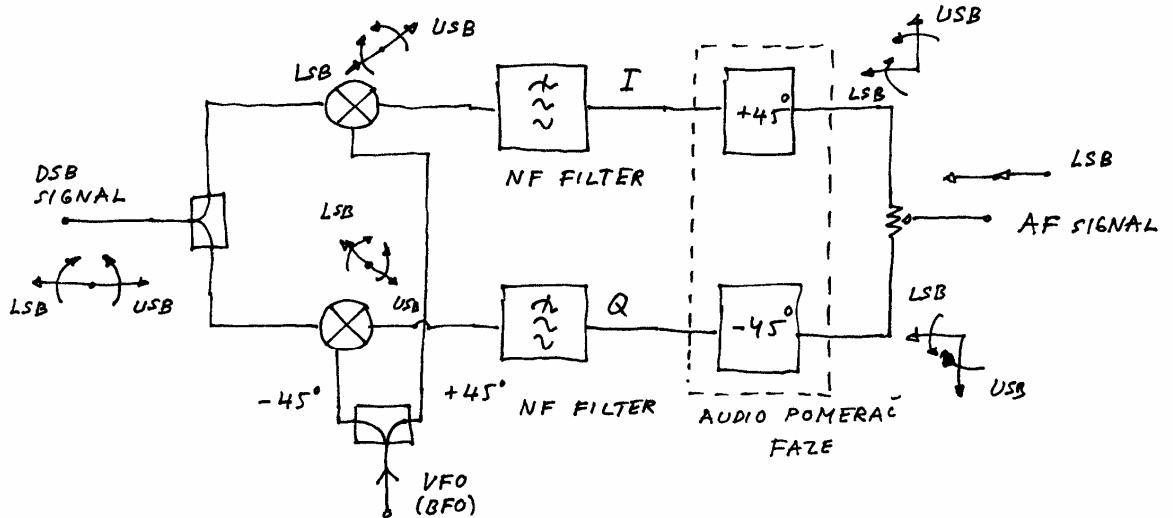

-AF loops and oscillations. This effect is happening especially when AF output amplifier drive speaker. The big gain in DC receiver, gain which is necessary for practical use, will cause voltage change in the lower signal stages and their detection. If we have bad parts or PCB circuits placement unwanted signals as parasitic modulations are amplifying to the clipping levels. The output signal is unpleasant for any listening. The solution for this phenomenon is to strictly obey rules for

good AF design with star ground configuration , Also it is necessary utility RC filter networks in power supply for every AF stage to prevent unwanted AF low frequency coupling.

Functional blocks in DC receivers which I will describe here are:

1. Input band pass filters
2. Mixers
3. Diplexer at the mixers input/output
4. AF low noise preamplifiers at the diplexer output
5. Dividers and phase shifters at LO (BFO) lines
6. Phase shifters (90 deg) at AF frequencies

1. Input band pass filters

Input band pass BP filters at mixer input are very important part of DC receivers. Their main purpose is to prevent mixer overload with unwanted out-band signals Author is person which like filters with coils without taps. Practical realization, without adequate equipments for measuring, is for not well experienced homebrew nightmare. It will case bad adjusted BP filters with big insertion loss IL. Bad or not well adjusted filter will lead to the bad RX sensitivity and greater AM sensitivity. The results will be big disappointment with realized receiver and DC technique generally. Good and relative simple BP filters are done in QST-u number 09/1988. How filter looks like see drawing down. Components values and filters selectivity characteristics are in the tables below:

band (MHz)	3,5	7	14	21	28
selectivity at other bands dB	<0,5	29	50	65	68
3,5	<0,5	29	50	65	68
7	30	<0,5	32	41	49
14	56	32	<0,5	16	40
21	63	44	8	<0,5	15

Band	C1/C3 (pF)	C2 (pF)	L1/L3 (uH)	L2 (uH)	centar f MHz
1.8	4000	400	2,2	22	1,75
3.5	2000	200	1,1	11	3,4
7	1000	100	0,55	5,5	6,8
14	500	50	0,28	2,8	13,6
21	330	33	0.18	1,8	20,7
28	250	25	0,14	1,4	27,4

Very good characteristic of K4VX filters is very small sensitivity to the component tolerance. They are initially designed for the well known multi-multi contest K4VX team The 100W transceiver outputs passed through BP filters to prevent unwanted noise desensitization on other bands. Similar filter with little better electivity but with C trimmers author published in CQQR 6/7 1985 magazine former YU QRP club. You can also find similar structure for tuneable band pass filter for all HF bands designed by author on these WEB pages.

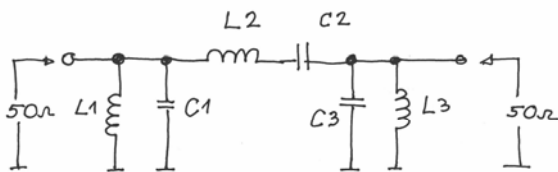

BP K4VX

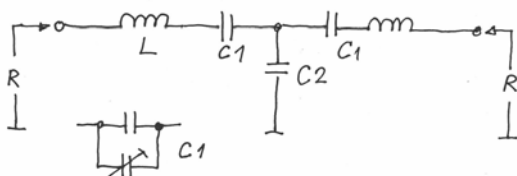

BP YU1LM

pic 3 BP Filters

R-input/output impedance (in our case it is 50 Ohms)

f1-lower -3 dB corner frequency (in Hz)

f2-higher -3 dB corner frequency (in Hz)

Formula for filter calculations are :

$$L = R / (2 * (f2 - f1))$$

$$C1 = (f2 - f1) / 2 * f2 * f2 * R$$

$$C2 = 1 / (f1 + f2) * R$$

We are obtaining L in (H) and C in (F)

BP filter have to be designed for bandwidth $B = f2 - f1$ the optimal bandwidth is between 10 % – 25 % of central frequency $f1$. If we carefully investigate formulas for BP calculation we can notice that for constant bandwidth B coil L have constant value and that it isn't frequency dependable parameter. Practical realization for filters at higher frequencies is now clear as problems if we like to have very narrow BP filter. It is very hard to obtain coil with very high Q parameter at higher frequencies to reduce BP filter IL. IL is growing if we decreasing wanted bandwidth. The filter which was realized by author are down, notice that component values are not according to the previously given formulas. The exact components values are changing also with filter response Gauss, Chebyshev....type see also article about BP filters for whole HF band which is derivate this design.

Filter for 14 MHz is $B = 1\text{MHz}$ $C1 = 15\text{pF} = 8.2\text{pF} + \text{trimmer } 3 - 9\text{pF}$, $C2 = 220\text{pF}$, $L = 7,8\text{uH}$.

Filter for 3,5 MHz $B = 0,5\text{MHz}$ $C1 = 120\text{pF} = 82\text{pF} + \text{trimmer } 60\text{pF}$, $C2 = 850\text{pF} = 820\text{pF} + 33\text{pF}$ i $L = 15,8\text{uH}$.

2. Mixers. Mixers or demodulators are the most critical component in DC receiver chain. The author built and tested in practice many different mixer types homebrew and professional products. Author also tested different mixers from his good friend Dusko YU1RK.. Without doubt DBM double balanced diode mixers with Schotky or Si switching diodes (1N4148 ...) are the best solution for DC receivers. (2007 I can notice that for HF switching S/H sample and hold mixers are the best choice for DC receiver realization. I shall write about this solution in part 2). Professional DBM products like SRA1 , SRA1H, SBL... have very small IL and first of all very good balancing in rejection unwanted frequencies (RF input and LO frequency). The bigger difference between professional and home made mixers is noticeable when we pass over the 100-200 MHz. Homebrew builders are not in position to find high quality ferrite rings, beads and matched diodes easy as factory can do. I am presenting here few different types of DBM for different LO drive and linearity characteristic. To prevent unwanted coupling and radiations to the rest of receiver it is very important that mixers are inside some closed metal box. I proposed also how to realize RF transformers for DBM mixers at input and output in IC sockets. To prevent thin coils from damages or break wires the best way is to glued transformers to the PCB or socket. This proposed realization solution is useful up to the 100 MHz -200MHz please take care that wire leads are short as possible if like to reach higher frequencies. The ferrite materials for transformers are necessary to be with adequate μ (permeability). For calculation and μ choice it is important lower -3dB corner frequency determined with formula.

$$Z = 6,28 * f * L = 4 * R = 200 \text{ Ohms (50OHms system)}$$

R is input/output impedance, in our case it is 50 Ohms. IL at lower corner will be less than 1 dB.

Useful hints for 50 Ohms system is that transformer or choke for lower corner has to be with next inductivity:

$$L = 31 / F$$

Where is $L=[\text{uH}]$ and $F=[\text{MHz}]$

For inductivity calculation with cores ring, air... it is very useful very nice looking freeware software "Mini ring core calculator 1.1 " written by Wilfried DL5SWB.

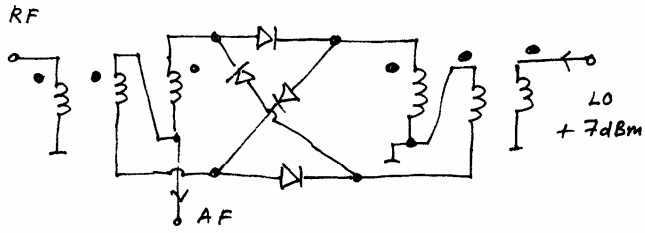

A) $1P3in$ $12 \div 18dBm$ (SBL1,)

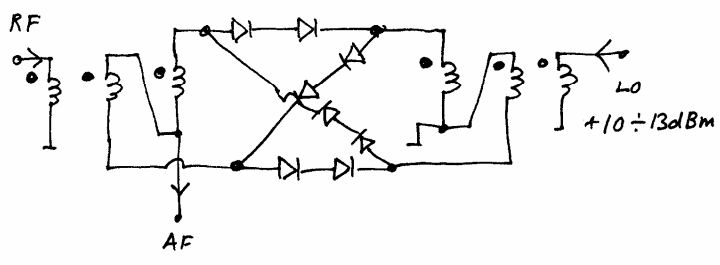

B) $1P3in$ $18 \div 22dBm$ (SBL 2 LH,)

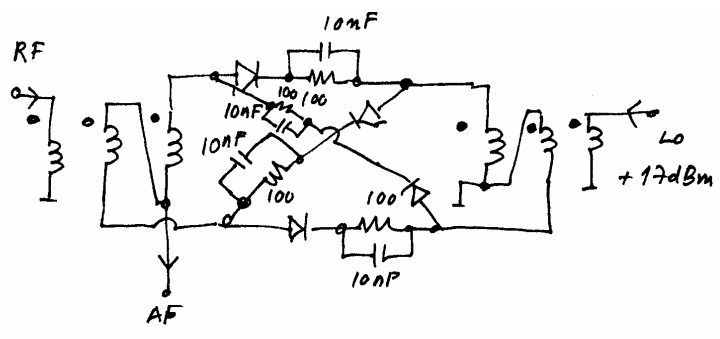

C) $1P3in$ $26 \div 30dBm$ (SRA1H,)

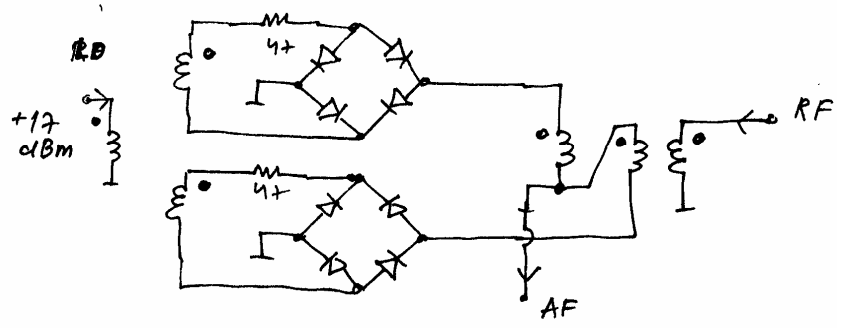

D) $1P3in$ $26 \div 31 dBm$ (SRA1H)

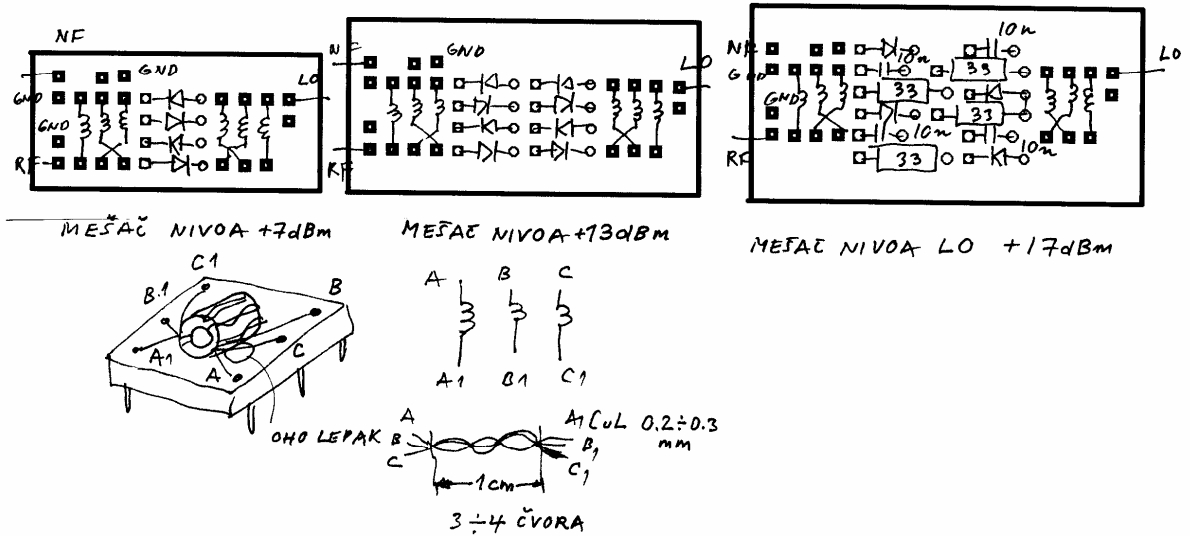
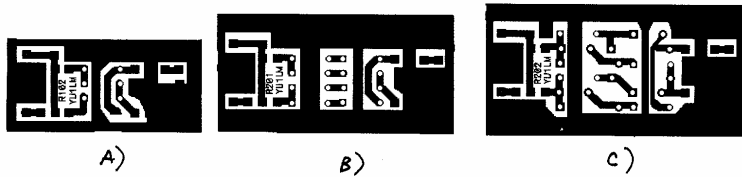

We can use ferrite ring core, ferrite beads like FT 37 43 is from Amidon. Also in this circuits are working TV "piggy nose", ferrite can be from the IF transformers. Please check that is ferrite core not conductive. The resistance has to be infinity. It is possible damage winding wires isolation at the sharp edges. The result of these damages is very strange mixer behaviour and it will be very hard way to find what is wrong. Instead Schotky diodes for DBM mixers HP2800 , BAS 40 , BA 482 or BAS 70 very good at HF will work 1N4148, 1N914 or similar. The transformer are wound with trifilar (3 wire) twisted wires 0,2 - 0,3mm CuL with 3-4 nodes at 10 mm length. This way of wounding way is important because at higher frequencies this twisted wires are behave as transmission line transformer. Other common used mixers in DC receivers like NE612 are very inferior in IMD (linearity) performances compared with diode DBM mixers but offer some mixing gain. IL insertion losses for the DBMs mixers are between -5 to -8 dB. The Motorola (Freescale) made DBM IC MC 13143 as Gilbert cell with extremely good linearity specifications. IP3in is 20dBm IC is working from 0 Hz do 2GHz and IC is in SO8 SMD package with DC power supply 6.5 V. IC is a very promising component for very good DC RX realization in future. IC specifications are 30 dB superior to common used NE612.(602). In this moment the most promising component is digital IC 74CBT3253. IC is 1 to 4 multiplexer with outstanding performances. Switching resistance at 30 MHz is in the range of 1-3 Ohms, according to data sheet less than 5 Ohms. IP3in linearity which was measured by N7VE is over 30dBm and mixer IL less then 1dB!!! This mixer has one more advantage in comparison to the other type of mixers it is leak RF phase shift network very important part for 2 and 3 DC RX types. Multiplexer IC 74CBT3253 is working also as SCF (Switching Capacitors Filter) and than we have one problem less in DC RX design/realization. There is nothing without disadvantage. IC disadvantage is LO (local oscillator) which is 2 times higher than input frequency. Very good results in DC RX design is possible achieved

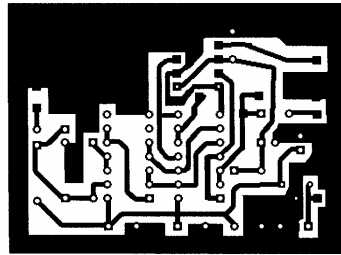
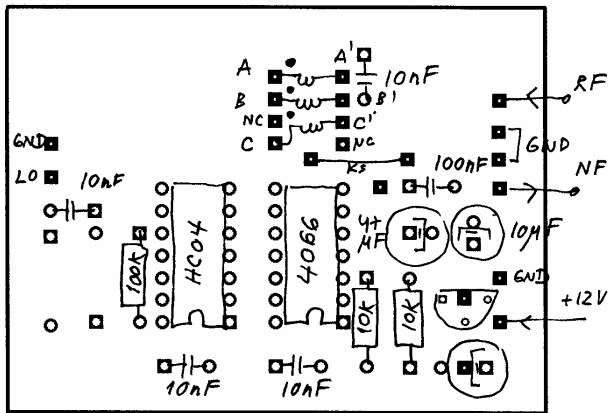

MEŠAČ SA 4066 RF DESIGN 6/95

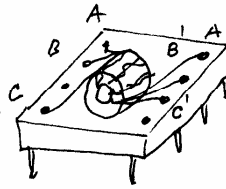

4. Diplexer networks To obtain optimum performances from mixers especially from diodes DBM diplexer network is very important. The correct terminations of all ports are very important. The good diplexer offer broadband termination especially for IF (AF) port. Diplexer design and IF termination was subject for the many articles. Author was checked many networks and he is recommending circuits **B, C, D**. My practical experiences are that for the big number different mixers the best is simple circuit **C** Wes W7ZOI also recommended them. It is also important to notice that solution with terminations 50 Ohms to the ground is not always the best solution for mixer best performances. Complicated diplexer network like has RX R2 built by KK7B is very good but very problematic for practical realization. For the DC receivers category 2 and 3 types are very important to match I/Q quadrature branches to obtain maximum rejection unwanted side band. It is important for coils built in diplexer that they are moulded it is one of ways how to prevent microphonic effect. We can calculate inductance starting with factory products data sheets, standard values or wounded on adequate "POT" ($A_l > 1000$) cores with 2 slices with.

Coil inductivity $L = A_l \times N \times N$ [nH]

A_l [nH/turn x turn] factory core parameter]
 N = full number of turns wound wire

With complicate network it is possible achieve selectivity close to the selectivity with crystal filter. Q_o of coils have to be high as possible to reduce IL to min, best ferrite cores and minimum quantity of wire. In many diplexer circuits authors didn't take care about these losses. When we write CKT for check analyzes with real components parameters we can notice reading results of analyzes that they are often quite different compared with results for ideal components described in articles. We have often few dB IL and IF port matching is far away from ideal component design. Unmatched IF diode DBM port will ruin DC RX DR(dynamic range) for the sure .

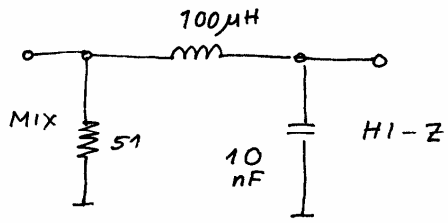

A) W7Z01

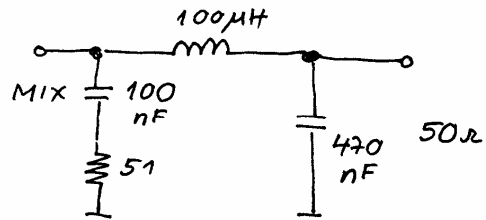

B) W7EL

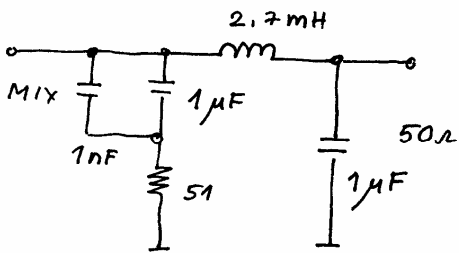

C) W7Z01 QRP.POP.NET

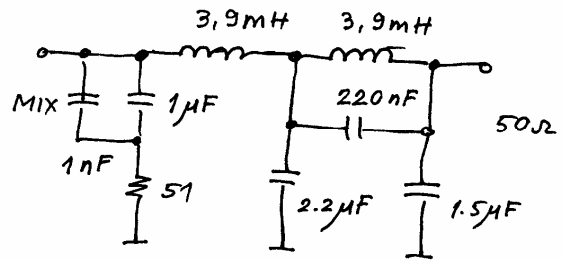

D) YU1LM (SSB)

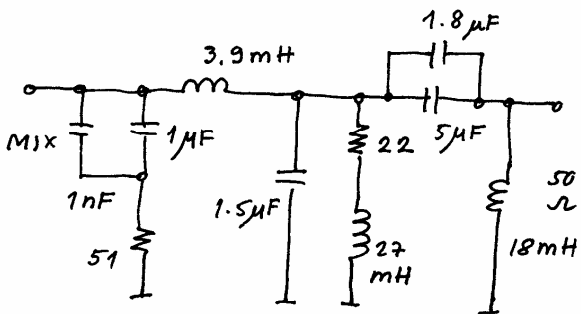

E) KK7B R1(R2) SSB

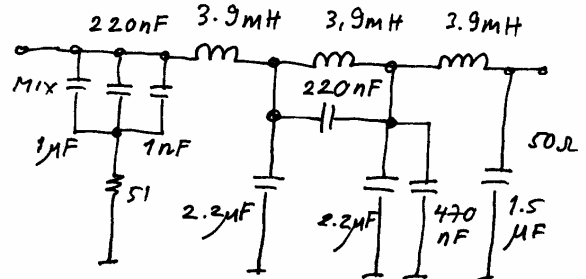

F) YU1LM -70dB (5KHz) SSB

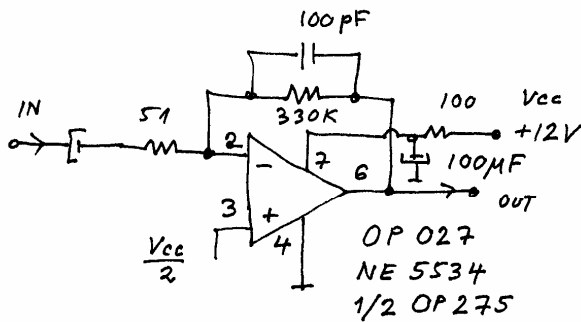

A) DL7AJY CQDL 3/91

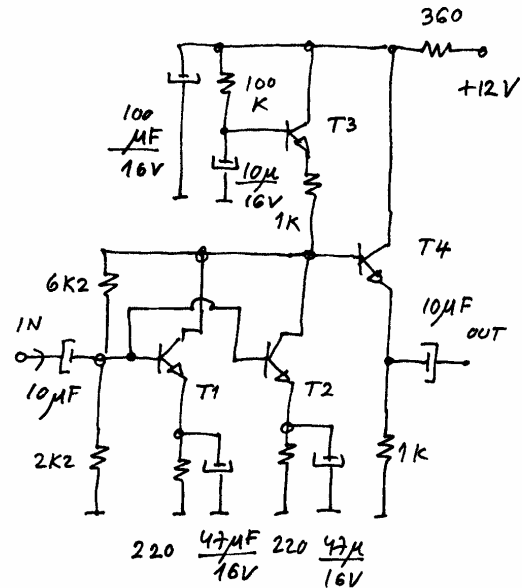

B) VE3... SVI TRANZISTORI
BC550 ILI SLIČNI MALOŠUMNI

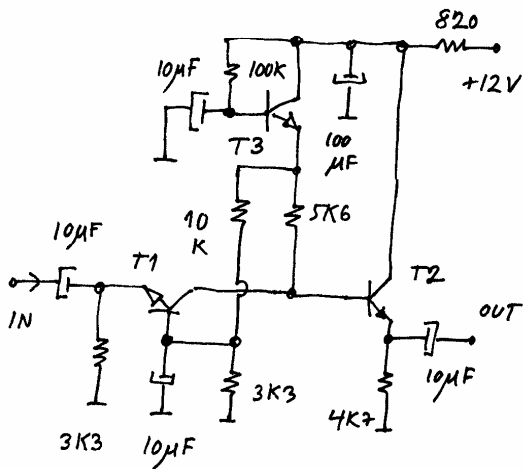

C) W7EL - SVI TRANZISTORI BC550
ILI SLIČNI MALOŠUMNI

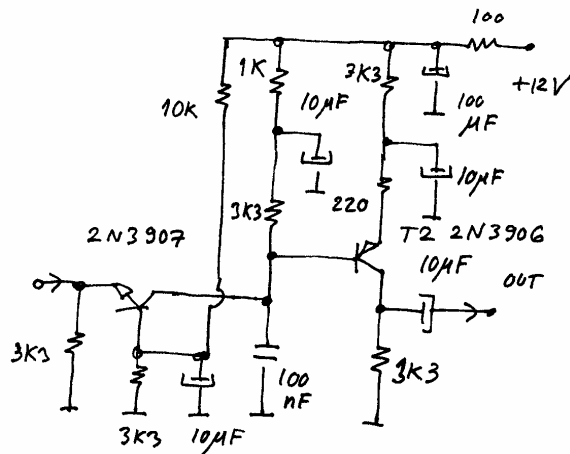

D) W7Z01 ARRL HANDBOOK
1994

AF post mixer preamplifier. After diplexer circuit we need to have low noise AF preamplifier with task to amplify wanted demodulated signal. Preamplifier must have small F (noise factor), high DR and of course that it has input impedance close to the 50 Ohms. Situation is similar in solving problem with preamplifiers for MC and MM head in audio. If we are looking through the different articles we can find many proposed solutions. The simplest solution for post mixer amplifier is to put low noise OP amplifier after diplexer. Unfortunately OPAMP amplifiers mostly haven't lowest noise when they are connected to the 50 Ohms source. One of possible solution is to transform 50 Ohms to the optimum OP noise impedance with AF transformer. AF transformers aren't solution which will be popular today and which will be widely used. N7VE is using in his RXs OP027 low noise OPA which has acceptable price (today 2007 we have much better OPAMP like AD797, LT1115 with much lower noise than OP027). With help special low noise transistor also it is possible achieve better noise performances but it is necessary match them. ICs like MAT3, MAT4 which are extra low noise matched differential pairs and can be one of solution for input post mixer amplifier stage but they are very expensive. Author was tested different solutions for post mixer amplifier but one stay as really best compromise. It is circuit W7EL proposed in his optimised QRP transceiver. W7EL proposed common base amplifier for input stage. The preamplifier NF is little over 2dB (with low noise transistors like BC550, BC413, ...) and it is widely used in many DC RX designs. Gain is over 30 dB typically 35 dB. 1dB compression is occurring with demodulated signal around 10 mV peak-peak or S9 +45 dB. Author designed similar amplifier but with only 20 dB gain which is giving better DR performances and it will be published in part 2. The

biggest advantage of common base connection is high isolations between input and output port. Similar very good solution is proposed by VE3DNL and we must have matched gain transistors. Here we have a very big advantage input signal is statistically speaking determined and noise is random process. If we have few parallel transistors overall noise will be decreased according to the next formula:

$$F_{total} = F \text{ individual transistor noise} / \text{SQRT}(n)$$

n= the number of paralleled transistors

With 4 paralleled BC550 transistors $\beta=200$ overall NF is around 0.5 dB. Some authors proposed connection with more parallel transistors. The authors has been tested 16 parallel transistors and achieved NF =0.2 dB. But we have to admit that it isn't easy job. the AF preamplifier will determine overall DC RX MDS(minimum detectable signal) or output noise without signal. Other transistors type like JFET didn't give comparable results and problem is also with impedance matching to the 50 Ohms. After this preamplifier it is possible connect some general purpose OP AMP and their noise figure is not so important parameter as it is for preamplifier. It is very important for good DC RX work limited AF bandwidth with combination HF and LP filters. If we investigate seriously bandwidth in some DC RX and not only DC RX it is very important that used bandwidth is limited several times in gain chain that used B in calculation for narrow filter in gain chain is valid.



Detectors and post-mixer amplifiers under C, D

5. Power dividers

Power dividers are also very important part of DC receivers. They can be in phase dividers and they can be broadband like it is PSC2-1 or similar product from Mini Circuits (1-500(750) MHz) or narrowband like Wilkinson divider is. For DC RX construction it is also important dividers with 90 DEG shift. To achieve better DC RX performances in image rejection good design is that 90DEG divider shifter is at LO side. Reason for this is that small amplitude unbalance typical for 90DEG divider will not produce any effect in decreasing image rejection. With sufficient LO drive even with 1 dB amplitude imbalance as difference will not produce any significant effect to the final result for image rejection unwanted side band. I gave several proposals for in phase and quadrature phase dividers and how to realize them. The builder choice is depending from he we want do and what he has to choose in solvages parts. Simple phase shifters are always narrow. The relatively simple and very good solution is proposed by KK7B for 14 MHz G realization. Phase shifter is working very well from 13.5-15 MHz for example and all other types are much narrow.

AF and RF phase shifters were very popular in 60th but also they were at "bad voice" in homemade tube SSB transmitters and receivers. The tube heating and unsatisfied component quality produced bad unwanted side (image) and carrier rejection in practical usage. Situation is quite different in this moment and it is quite opposite to the 60th. Components quality are now very good, also it isn't "big" problem to purchase them for the most builders all over the world. This situation is challenge for the builders to revival old technique now at new modern way. It is not unusual to achieve good results 60 dB image rejection relatively easy even. Purchasing components with 1% or better tolerance are now relatively easy task ordering them from (Muplin, Burklin, ...) I/Q technique are now quite common thing for most transceivers at last IF LF (low frequency) 10-50 KHz with DSP processors. I/Q receivers are very popular in new technique SDR (software defined radio) also see some mine realization on this WEB pages.

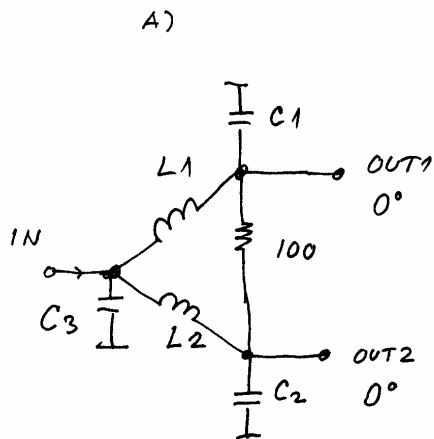
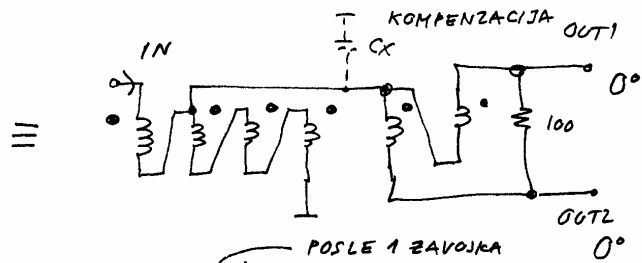
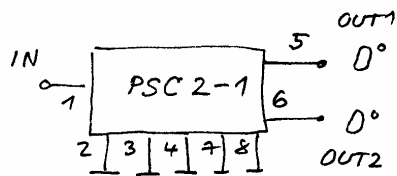

$$X_{C3} = 35 = \frac{1}{2\pi f \cdot C3}$$

$$X_{L1} = X_{L2} = 71 = 2\pi f \cdot L$$

$$X_{C1} = X_{C2} = 71 = \frac{1}{2\pi f \cdot C1}$$

D) Wilkinson

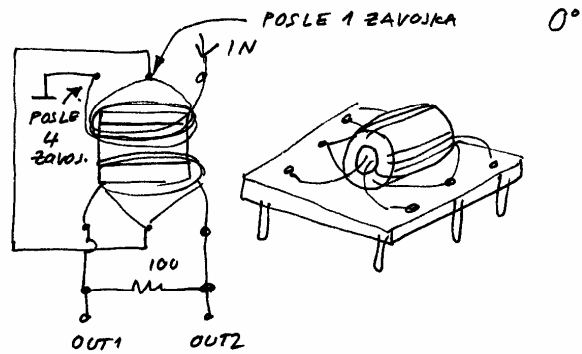

B) PRAVLJENJE DELITELJA U FAZI

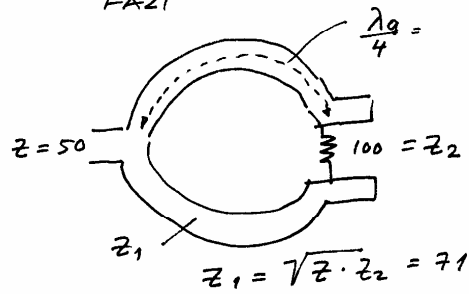

E) Mikrostep Wilkinson

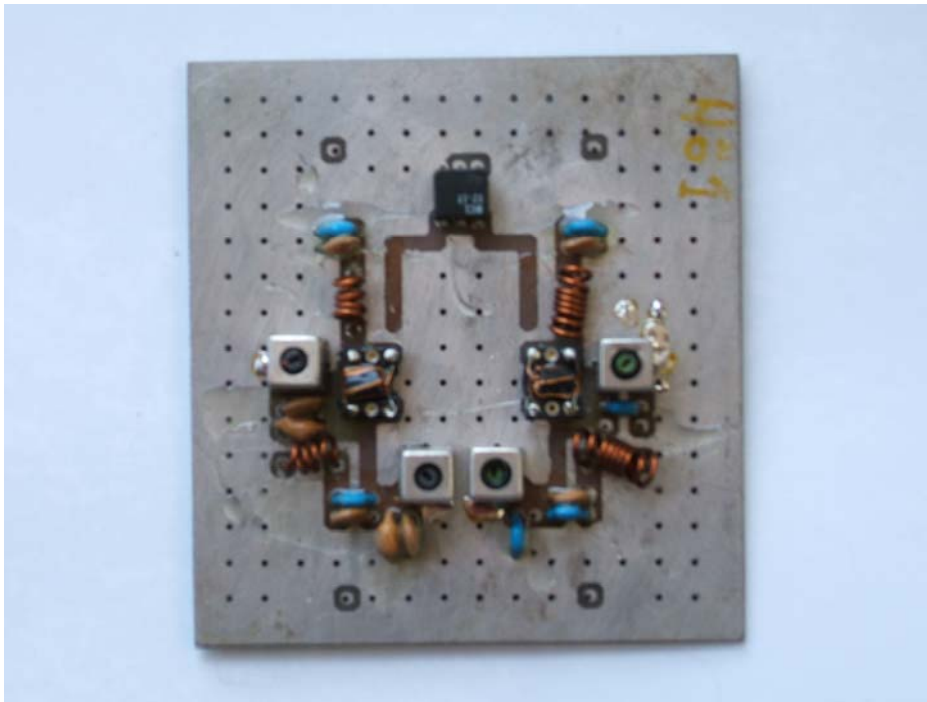

RF phase shifter 25-150MHz under F designed and realized by author

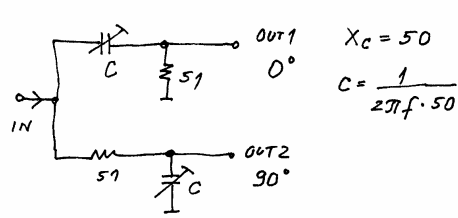

$$X_C = 50$$

$$C = \frac{1}{2\pi f \cdot 50}$$

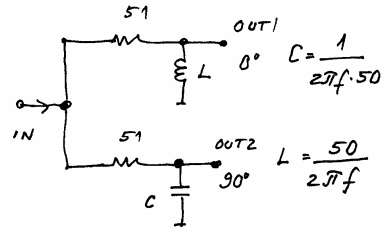

$$C = \frac{1}{2\pi f \cdot 50}$$

$$L = \frac{50}{2\pi f}$$

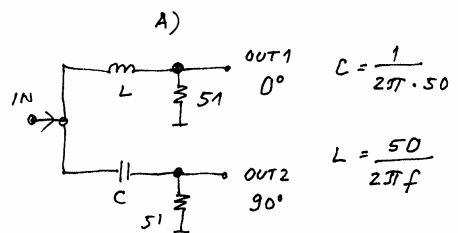

$$C = \frac{1}{2\pi \cdot 50}$$

$$L = \frac{50}{2\pi f}$$

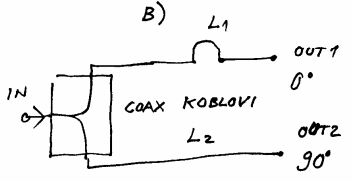

DELITELJ U FAZI
 L₁ VEĆE OD L₂ ZA $\frac{\lambda_g}{4}$
 ZA RG174 $\lambda_g = 0.67\lambda$

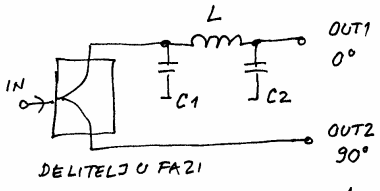

DELITELJ U FAZI

$$X_{C1} = X_{C2} = 50 = \frac{1}{2\pi f \cdot C}$$

$$X_L = 50 = 2\pi f \cdot L$$

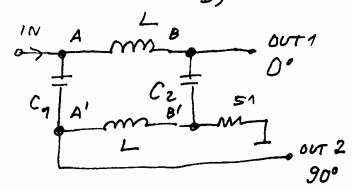

KK7B SPRAAT 192

$$X_L = 50 = 2\pi f \cdot L$$

$$X_{C1} = X_{C2} = 100 = \frac{1}{2\pi f \cdot C}$$

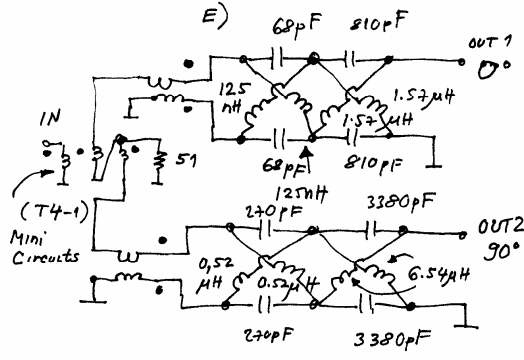

F) 2 ÷ 30 MHz

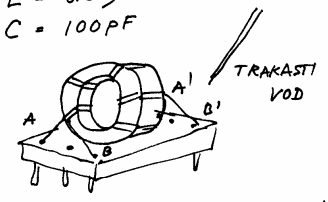

FINIM POMERANJEM NAMOTAJA
 NAMEŠTA SE NAJBOLJE POTISKIVANJE
 PRE FIKSIRANJA "OHO" LEPKOM

G)

First type DC RX.

It is a simple as possible DC RX type. The biggest disadvantage of this type is that we have twice more signals than they are existing in the air practically. I gave two first type DC RX one from W7EL (ZL2BCW realization) with my PCB realized successfully several times. I also made similar DC RX with audio AGC (automatic gain control). This RX will enable much pleasant and comfortable receiving AGC range is around 45 dB and starting from very big input signals levels. This kind of receiver has very good reproducibility and they are very good start point in homebrew DC RX field. It is very important to notice how very good audio receiving quality they enable. Two identical RX first types enable combining with RF/AF phase

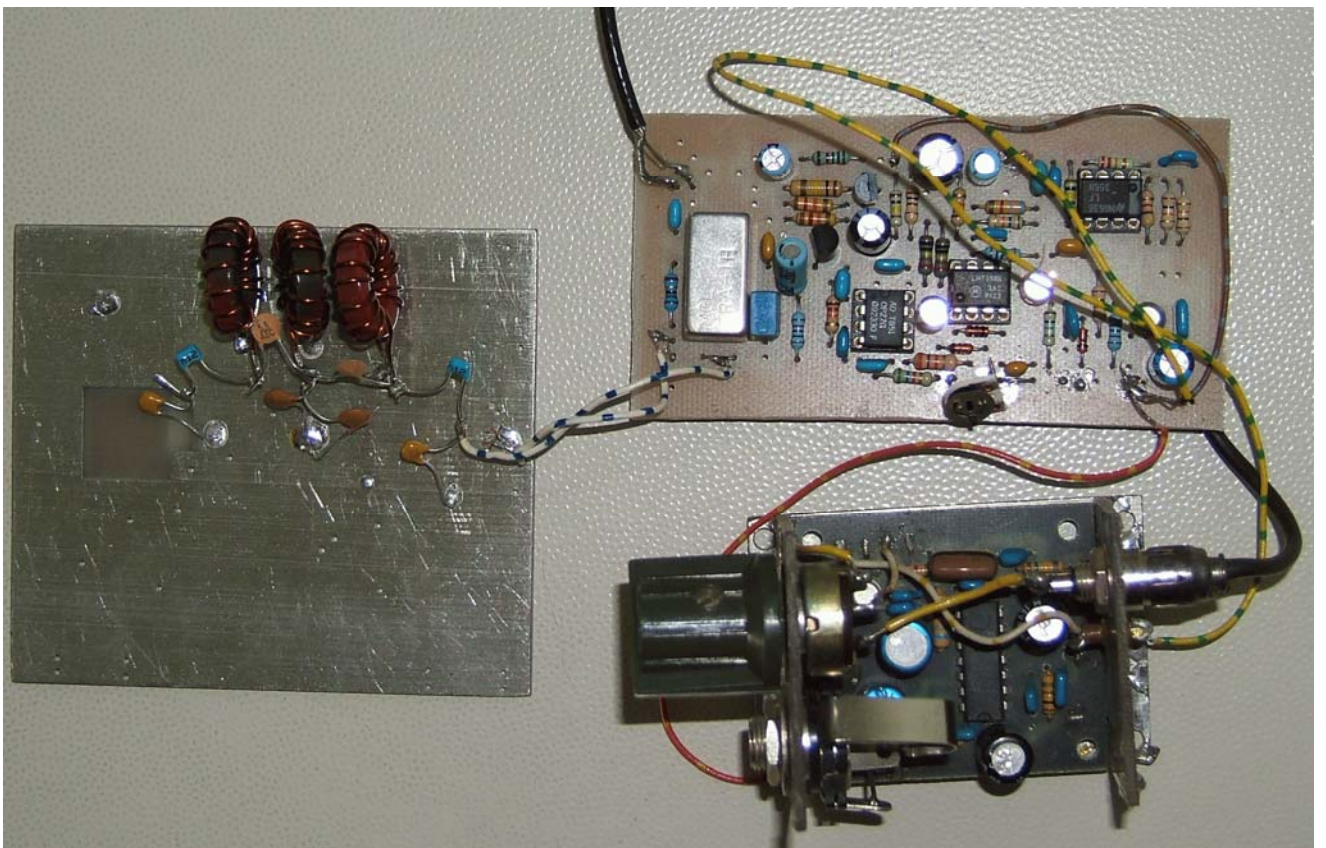
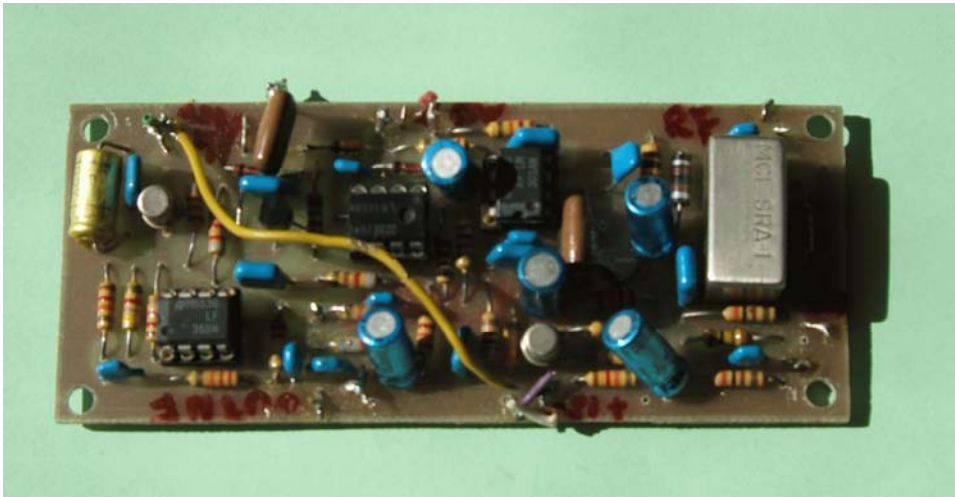

W7EL DC RXs built by author

around 1%) and 5% tolerances can pass. Image rejection from 60 dB is not so strange. The circuit which is driving mixers it possible use for Weaver receiver also. Image rejection in function of phase errors I am presenting in table down:

Phase error (deg)	image rejection(dB)
0.125	60
0.25	53.24
0.5	47.16
1	41.11
2	35.01
3	31.42
4	28.85

These results in table are if we haven't amplitude imbalance between I/Q branches. If it is not true than we have additional loss determined with amplitude imbalance also. The poly-phase AF networks have losses which are going from 6-11 dB!

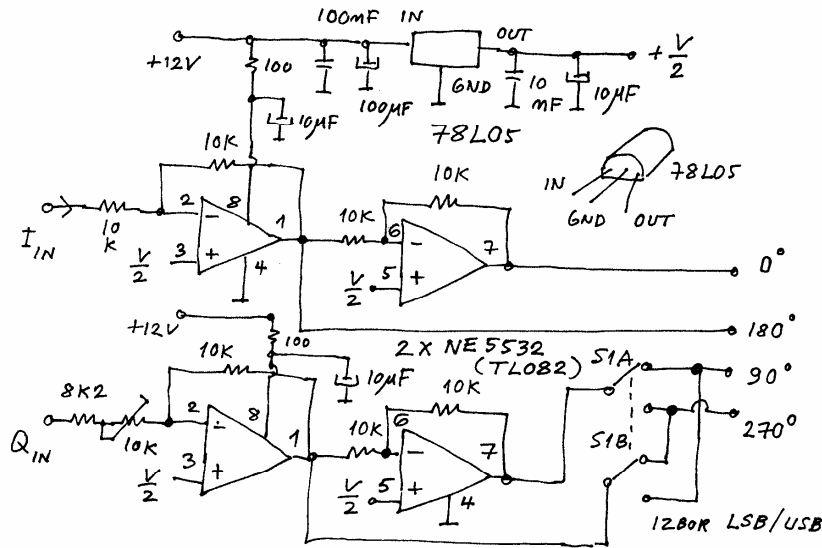

POBUDA ZA POLIFAZNI POMERAČ FAZE ILI DEMODULATOR 553MV

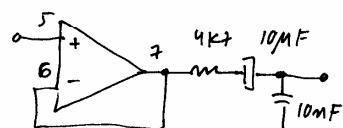
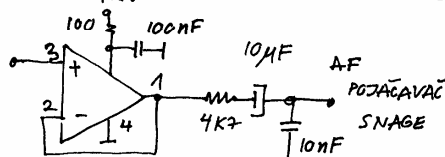
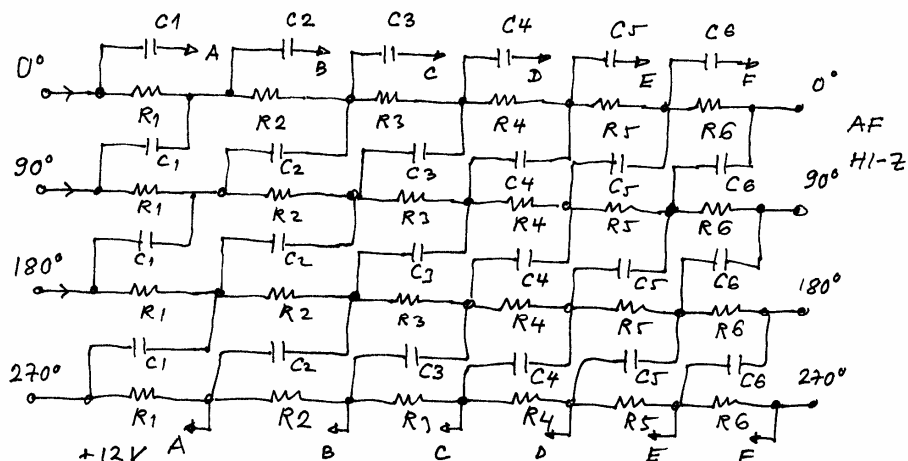

VERZIJE

- A) $R_1 = R_2 = R_3 = R_4 = R_5 = R_6 = 12K$
 $C_1 = 22nF + 22nF, C_2 = 33nF, C_3 = 10 + 10nF, C_4 = 10nF, C_5 = 5,6nF$
 $C_6 = 4,7nF$
- B) $R_1 \dots R_6 = 10K, C_1 = 47nF, C_2 = 33nF$
 $C_3 = 22nF, C_4 = 15nF, C_5 = 10nF, C_6 = 5,6nF$
- C) $C_1 \dots C_6 = 10nF, R_1 = 47K, R_2 = 33K$
 $R_3 = 22K, R_4 = 15K, R_5 = 10K, R_6 = 5,6K$

POLIFAZNI POMERAČ FAZE U AUDIO OPSEGU SA "BUFFER"-OM

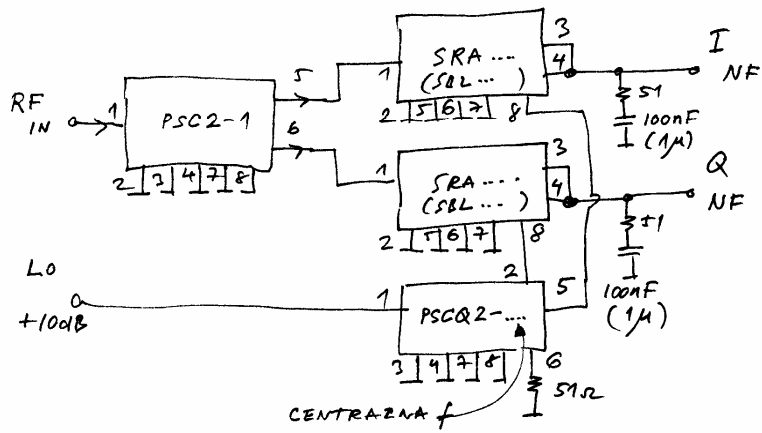

F) I-Q (KVADRATURNI DEMODULATOR) ZA PRIJEMNIKE 2 i 3

Third DC RX type or Weaver DC RX type

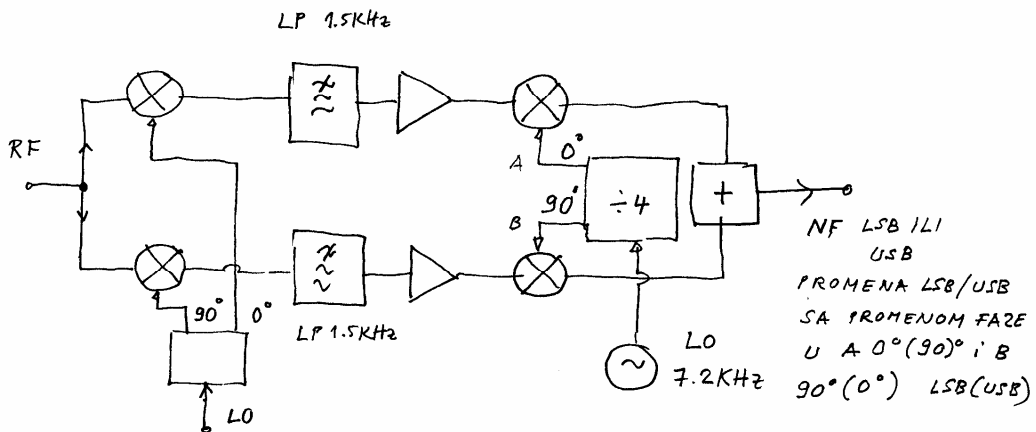

WEAVER-0V DEMODULATOR DC PRIJEMNIK TIP 3

The third DC RX type is RX which is eliminating image according to the Weaver method or third method for SSB demodulation. The simple as possible explanation for Weaver method is that audio phase shifting is now moved to the audio bandwidth sub carrier digitally from 1200 –1700 Hz. The frequency spectrum which we have after modulation with additional sub carrier now is very complicate to understand. It's seem to us that it isn't possible extract wanted side band at first moment. The block diagram for the Weaver DC RX is at drawing up. The Weaver method is starting from facts that human voice has very small components in frequency range of additional audio sub-carrier. Or we can say that is human voice "empty" in this range and than audio

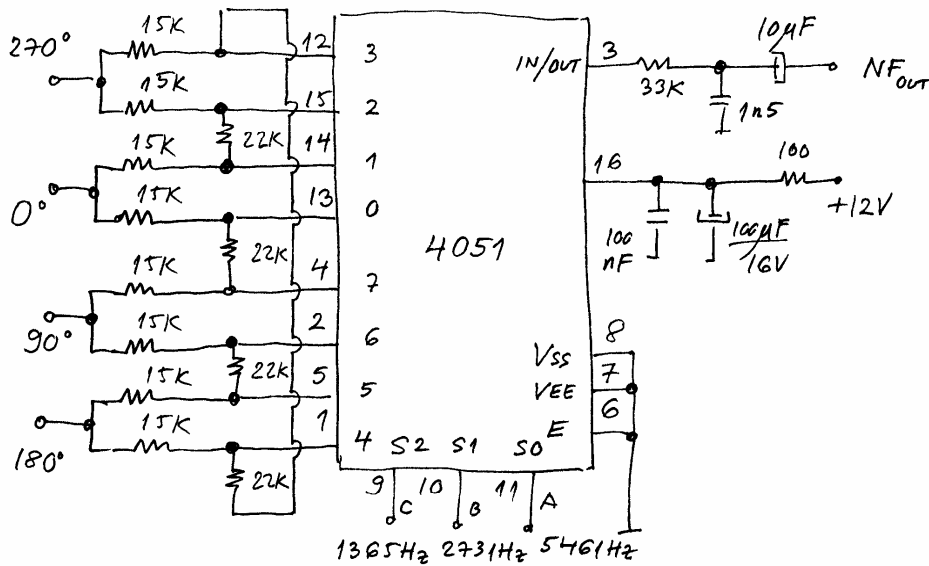

WEAVER-0V POLIFAZNI DEMODULATOR 553MV

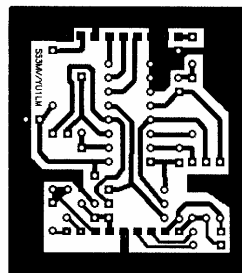
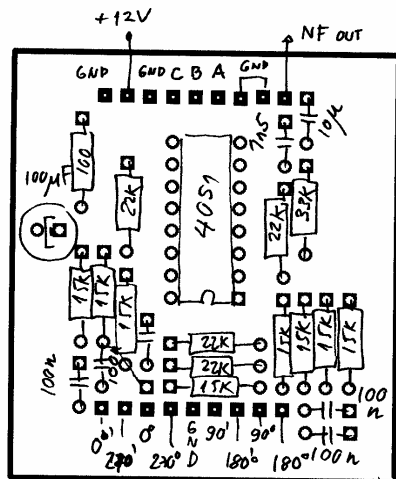

" " KADA TREBA DA SE ELMINIŠE DC (JEDNOSMERNNA) KOMPONENTA

components are not so important for readability. USA space agency NASA had been used in space communication during the travel to the moon this frequency range for astronauts body telemetry. As idea Weaver demodulator looks like an ideal solution but not as it seem at first moment. We need to build in very sharp filters for the rejection unwanted voice modulated

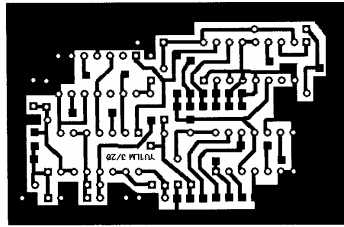
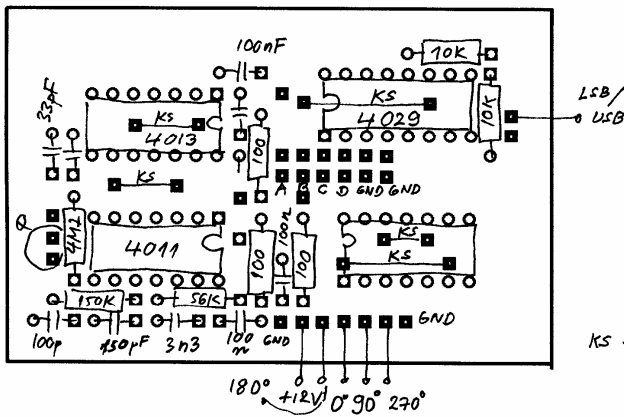

KS - KRATKOSPojNIK

GENERATOR TAKTA ZA S53MV/DK7JD DEMODULATORE (U SLUČAJU KORIŠĆENJA Q 3n3 KRATKOSPojNIT)

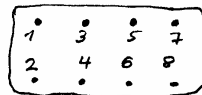
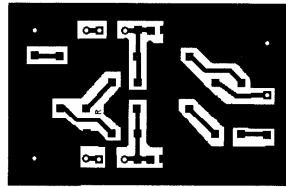
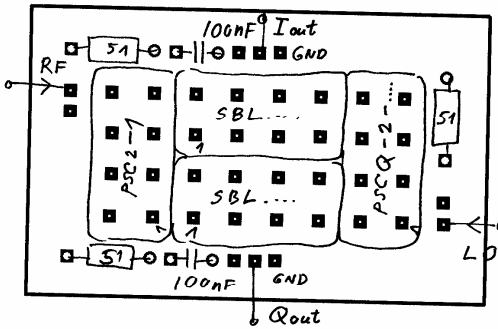

POGLEd ODOZDO

I-Q DEMODULATOR ZA PRIJEMNIKE 213 TIPI SA MEŠAČIMA, DELITELJIMA I POMERAČIMA FAZE MINICIRCUITS

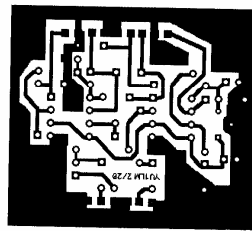
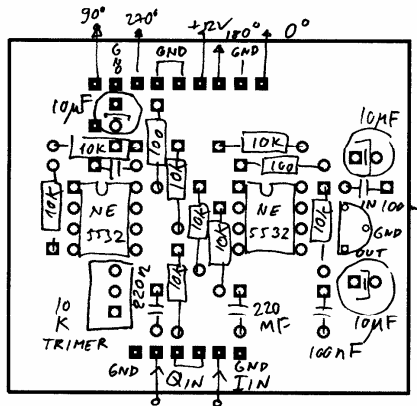

DRIVER ZA POLIFAZNE SISTEME N7VE, S53MV...

"components". The sub-carrier which is in the middle of the audio range has leakage and it can be heard during receiving process. As it is normal for second type DC RX it is also for Weaver RX good match between I/Q branches are very important for achieving good final results in image rejection. For the Weaver receivers I proposed two type digital sub-carrier generators in one. The first circuit is using cheap quartz crystal from watches 32768 Hz . The circuit has oscillator with IC 4011 and divider with ratio 3 realized with IC 4013. Output signal frequency 10922 Hz is going to the IC 4029 which is UP/DOWN counter programmed to divide with ratio 16. At 4029 output we have next frequencies 5461 , 2731 , 1365 i 687 Hz which are necessary for microwave demodulator an modulator designed by Matjaz Vidmar S53MV(ex YU3MV) published in CQ S5 magazine or at Internet site WWW. HAMRADIO.SI. The second Weaver demodulator modulator has been published in CQ DL 12/1984 magazine by DJ7KD. Wanted side band selection we are choosing with counting direction UP or DOWN. The wanted audio sub-carrier we are obtaining dividing frequency 5461 Hz with 4 in IC 4014. For the modulation and demodulation process we are using ICs 4066 (CD or HEF). IC 4066 is working as double balanced DBM mixer. The wanted side band selection is very easy obtaining with change phase position audio carriers in demodulator/modulator circuit. Matjaz S53MV is using poly-phase system for demodulation realized with multiplexer 1 to 8 CD4051. If we connected control signals to the resistive network we are combining different outputs and we demodulated SSB wanted side band (LSB or USB). Used circuit is relatively simple but fact is that we are using poly-phase system for SSB generation/demodulation and that it is with used ICs frequency limited.

IF we make simplified RX analyzes as I told it is very important used bandwidth not only at beginning but also at the end of RX chain. This simplification with narrowest bandwidth is true only if we haven't too much more gain after narrow bandwidth point in

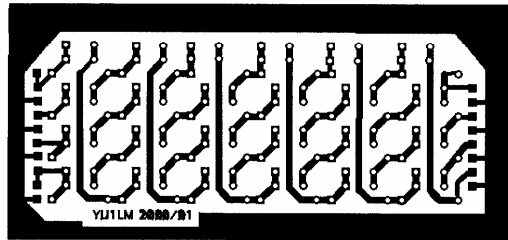
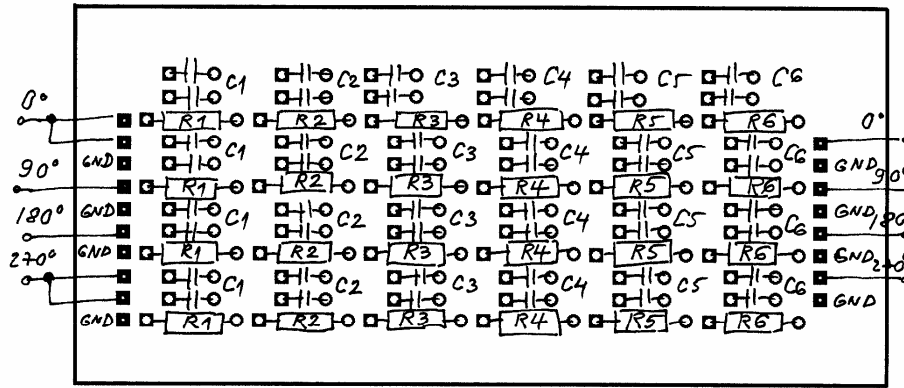

AUDIO POLIFAZNI POMERAČ FAZE

RX. In case DC receivers it is not true it is quite common gain from 60 – 100 dB after the most selective part mixer diplexer. To keep on projected DC RX performances it is necessary to limit audio bandwidth with LP filters $f_c(-3dB)$ 1,2kHz (CW) and 2,4 kHz.(SSB) before the final audio power amplifier. The practice lead that are best LP filters A. very good results is offering LC filters but they are not so easy for realization B. The SCF (switching capacitors filters) are very good filter type. They enable very easy way for changing filters 3dB corners. The MAX 293 is very good choice for SCF and it was popularized locally by well-known designer Mirko YU1AD in magazine Radio Amater YU. It is very important to notice that SCF use is useful when the input AF levels are big enough for example 1V. At the small input levels SCF will ruin input S/N ratio with their distortions and internally generated noises(see data sheets). If we are talking about personally impression built in LP filter will dramatically improved impression about sound quality and readability of incoming demodulated signals.

We have one circuit at the end of DC RX which is also very important it is audio power amplifier. The most reader will think that influence of audio power amplifier is very small to the overall DC RX specification.

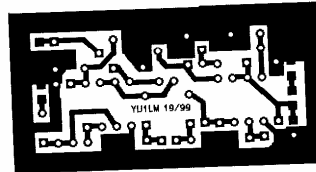
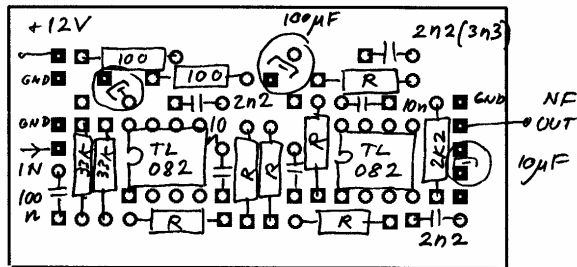
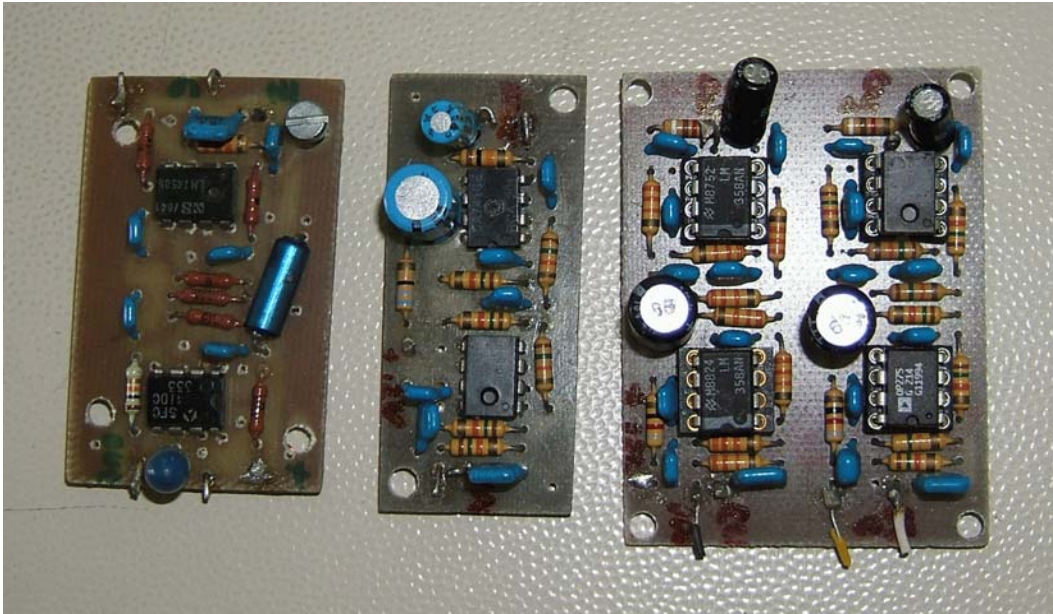

AKTIVNI AUDIO LP FILTER CQ DL 6/82

The very often used AF power amplifier like it is LM386 very cheap and economic IC but isn't good choice for any serious design. The IC LM386 generates noise as "Niagara waterfalls" and it offer 40 to even 70 dB gain which we can find in different designs. I proposed the schematic with circuit to reduce broadband noise if we still want to use them. AF power amplifier gain for the good DC design is in range from 20-26 dB. I recommend direct replacement for the LM386 power amplifier SM 2211 from the National Semiconductor. The much better AF amplifier is TDA 2003 car radio amplifiers used also in many designs. It is offering much better linearity, lower noise and if we compared them with LM386 which is 1W amplifier it will give very good 4W which is good headroom for AF power amplifier. I am using headphones for receiving all previously mentioned problems with noise and linearity will be noticeable much easy. At the end I am proposing very good HI-FI headphone amplifier output power 100mW and gain 15 dB designed from my good friend Rade Pavlovic.

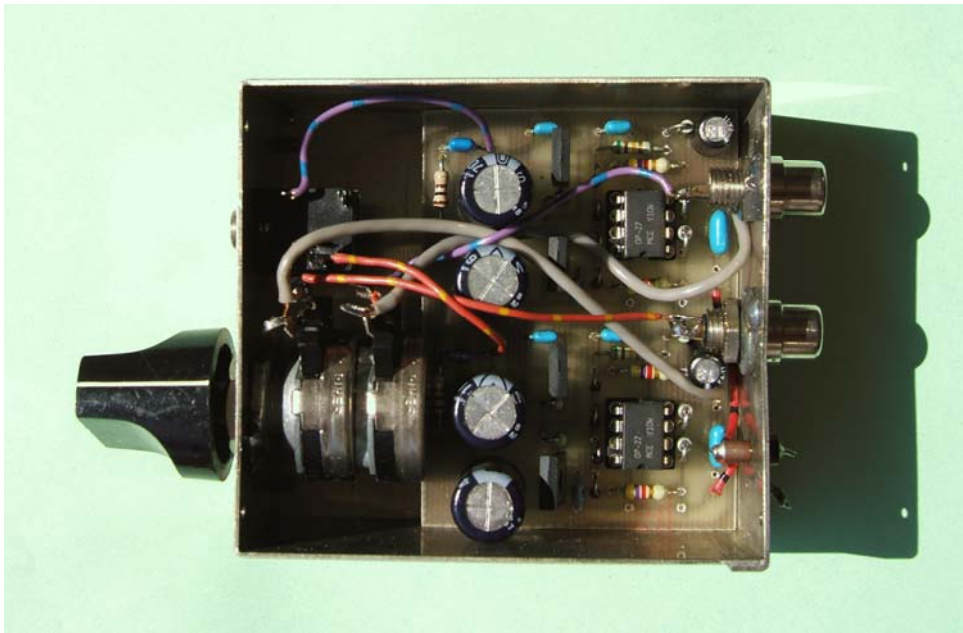
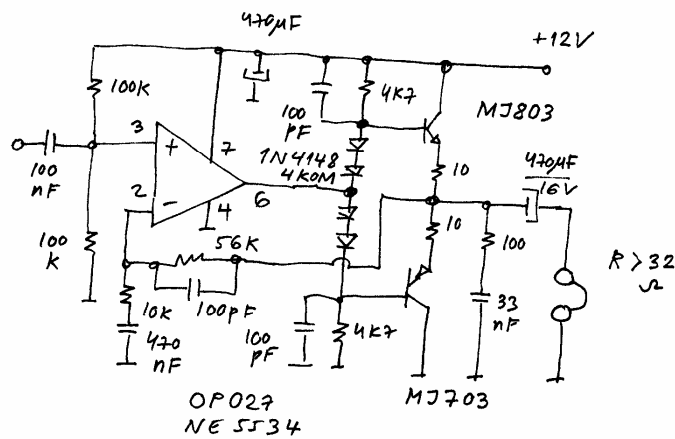

At the end of this article is HF/VHF DC transceiver design proposal which I started with my old friend and QRP enthusiasts Goran YU1GD and Miki YU1KM. The idea was that we together realize DC QRP transceiver and use good side of DC design. The first high IF is similar to the most modern transceivers like IC706 ,FT100...and it is between 50-70 MHz. High IF will enable image rejection for more than 70-80dB. The DC receiver and transmitter are for relatively narrow bandwidth 100-500kHz and it is relatively easy to achieve good results for such narrow bandwidth. Problem with LO I solved with "super VXO" which started at 10 MHz and which covering IF bandwidth with good stability. For general covering transceiver it is relatively easy realization of synthesizer with big steps 100-500 kHz or for first help crystal oscillator one or 2 per one band. I have notice that after 7 years we didn't finish what we planned. Some parts are realized and tested but not all blocks like it is proposed. One of reasons except miss free times to unfinished idea is my new preoccupations with new DC technique SDR (software defined radio) which offer much more possibility with same hardware but fundamentals are very similar

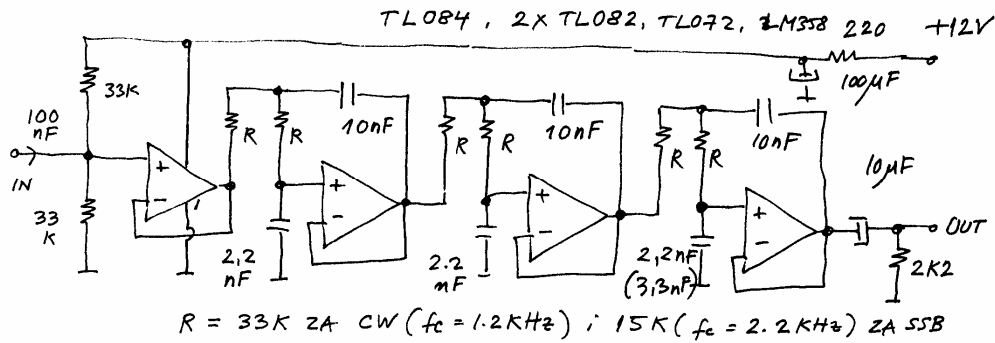

A) ARRL HANDBOOK 1994 AKTIVNI LP FILTAR, CQDLG/82

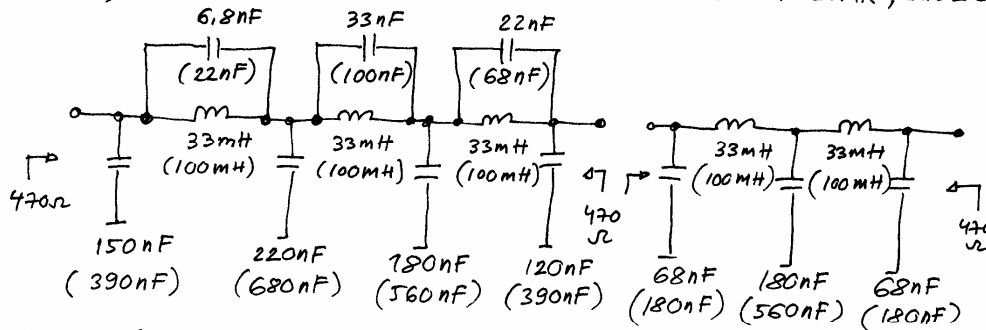

B) LPSSB (CW) FILTERI IZ PRIJEMNIKA R1 (R2) KK7B QST 8/92

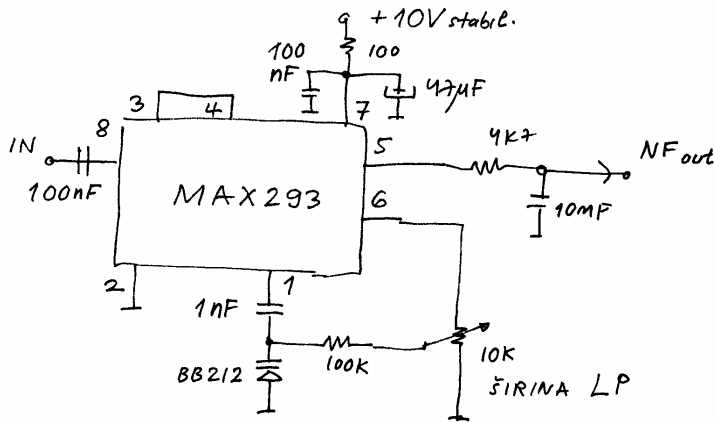

C) SCF PROMENLJIVI LP FILTAR

I am pleased to offer my thanks to all who gave me support in article writing specially to my old friend world well-known RF designer Drago YU1AW who succeed me to carry my DC receiver design experience to paper (www.qsl.net/yu1aw Drago is man who first built the biggest amateur 12 m EME antenna more than 30 years ago also he is high power HF,VHF,UHF amplifier designer, low noise preamplifier designer....) I have to apologized for mistakes please send me your comments and photos to my E-mail address.

STASIC@eunet.yu
Tasa@insimtel.com

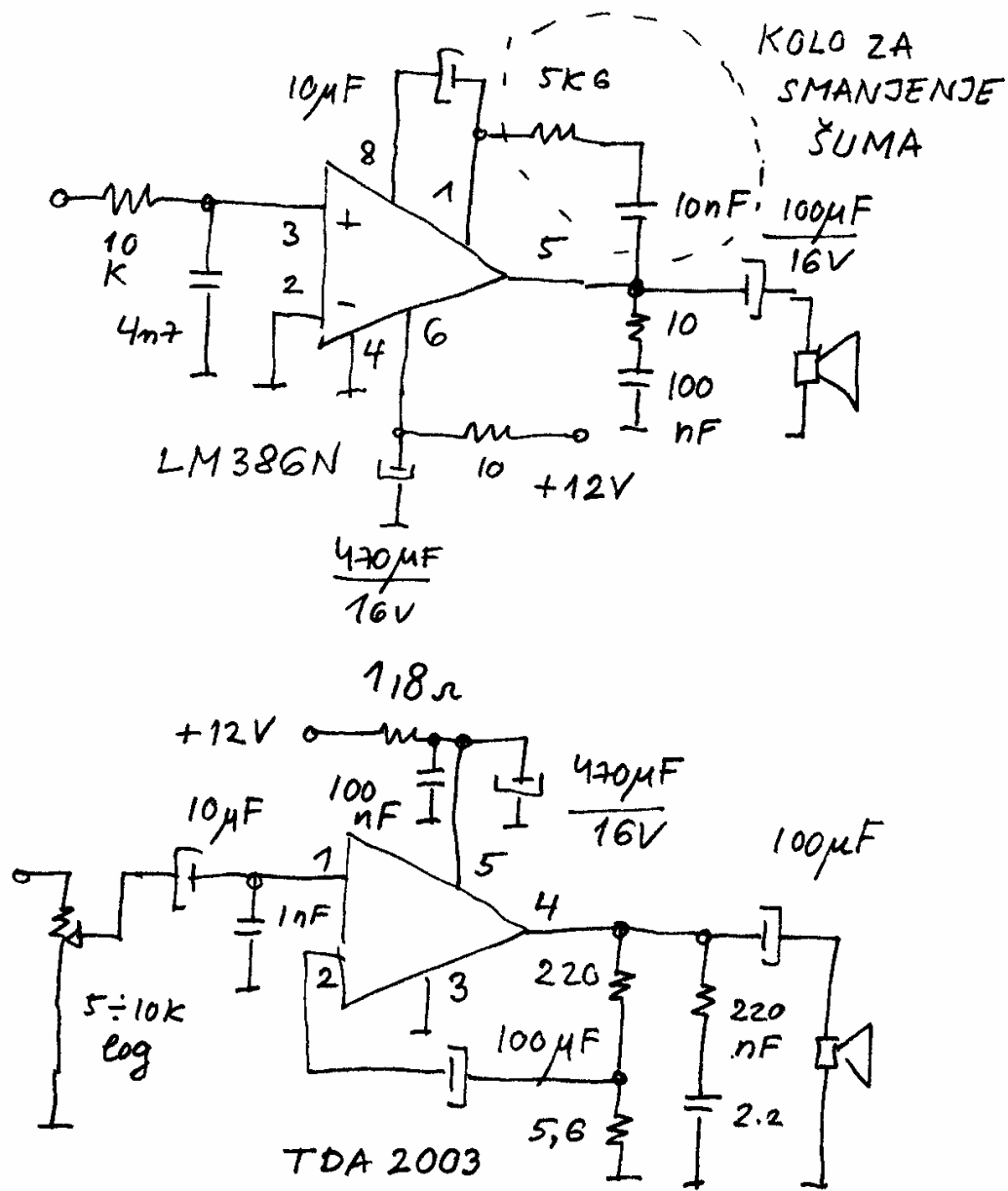

HINTs

[All PCBs are scanned and dimensions are not good for direct printing.](#)

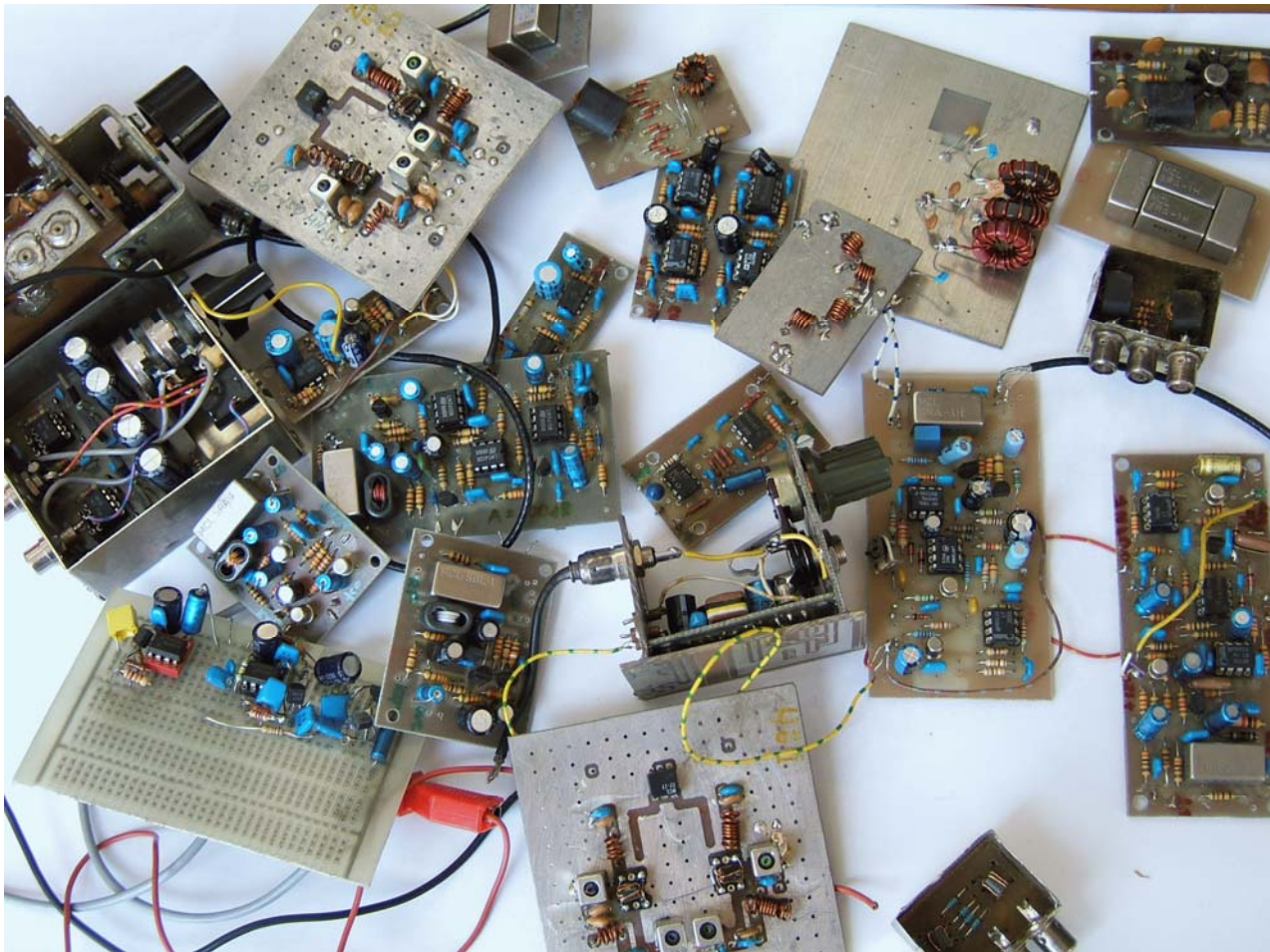

Parts, subassemblies and complete DC RXs built by author

References:

1. 80m SSB Transceiver nach der dritten Methode Burkhard Kainka DK7JD –CQ DL 12/1984
2. High-Performance Direct-Conversion Receivers Rick Campbell KK7B – QST 8/1992
3. High Performance, Single – Signal Direct – Conversion Receivers Rick Campbell KK7B – QST 1/1993
4. An Optimized QRP Transceiver Roy Lewallen W7EL – QST 8/1980
5. A Multimode Phasing Exiter for 1-500 MHz Rick Campbell KK7B – QST 4/1993
6. Single Conversion Microwave SSB/CW Transceivers Rick Campbell – QST 5/1993
7. Single Sideband Systems@ Circuits William Sabin @ Edgar Schoenike McGraw Hill 1987
8. 40-m-Konverter mit IP3=+30dBm Wolfgang Schneider DJ9ES – Funk Amateur 12/1996
9. Phasing-Type SSB Generators / Demodulators John Hey G3TDZ – Radio Communication 6/1991
10. A Passive Phase – Shift Network to Cover the Whole Band Rick Campbell KK7B – SPRAT 1995
11. The G3TDZ Phasing Receiver John Hey G3TDZ - -SPRAT 1985
12. QRP-CW Transceiver fur Kurzwelle Frank Sevke DL7AJY – CQ-DL 3/1991
13. Transceivers With IF Zero for 1296 MHz Matjaz Vidmar S53MV www.hamradio.si
14. ARRL Handbook 1994
15. A Polyphase Receiver John Hey G3TDZ – SPRAT 1986
16. 15 Meter Sideband Transceiver Douglas Glenn WA4ZXF – Ham Radio 3/1983
17. The “Ugly Weekender “ Adding a Junk Box Receiver Roger Hayward KA7EXM – QST 6/1992
- 18 2 meter transmitter uses Weaver modulation Norm Bernstein N1COX – Ham Radio 7/1995
19. Bandpass Filters for HF transceivers Lew Gordon K4VX – QST 9/1988
20. Direct Conversion CW Receivers Steve Price G4BWE – Radio Communication 1/1986
21. Der Direktmischer das Unbekannte Wasen Rudolf Burse DK2RS –CQ DL 6/1982
22. Prijemniki pramogo preobrazovanja dlja ljubiteljski svzji V.Poljakov RA3AAO DOSAAF 1981
23. Ringmischer mit Vierfach HCMOS Schalter Hans Joachim Brandt DJ1ZB – QRP Raport 1/1997
24. QRP Primopredajnik Milorad Todorovic YU1WR – Radio Amater 7,8,9 /1986
25. <http://qrp.pops.net/qrp/> sait devoted to Doug De Maw- W1FB from friends W7ZOI ...

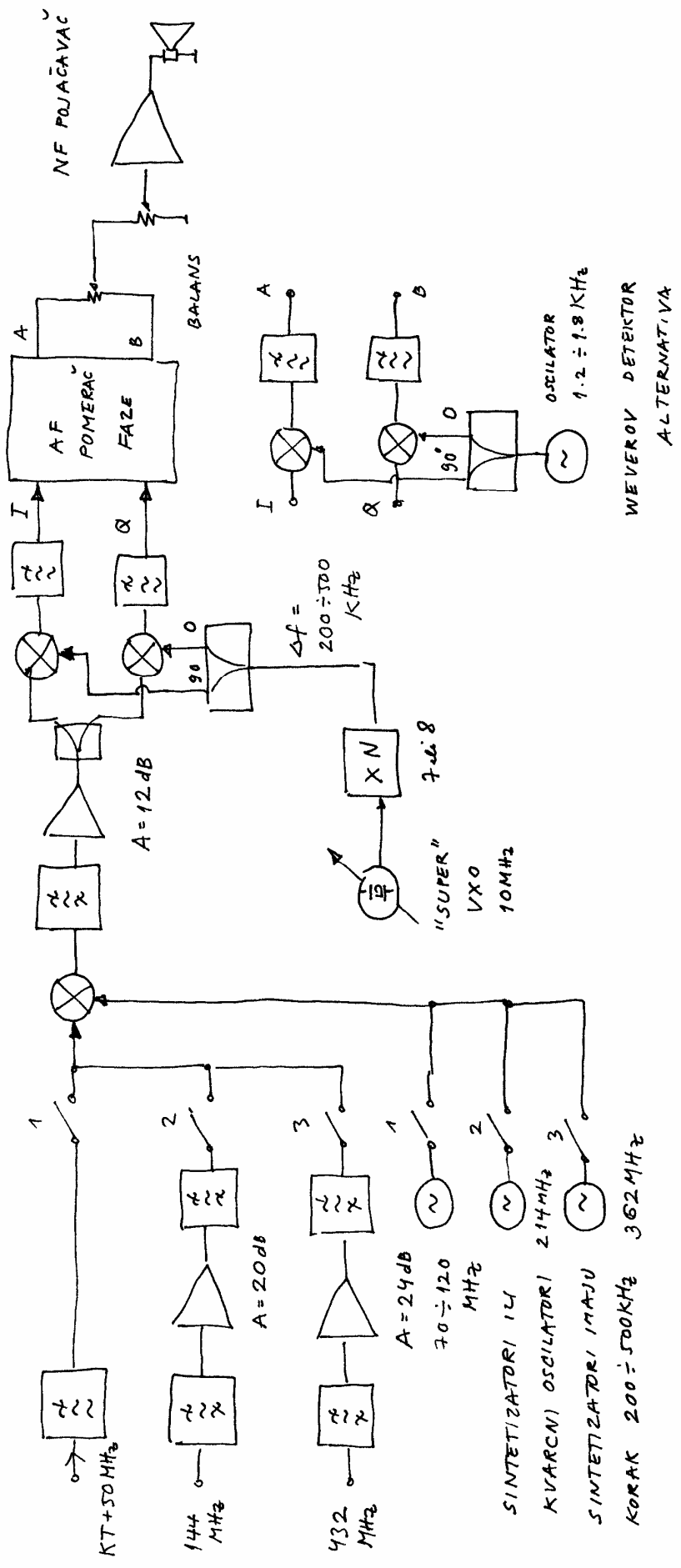

WEVEROV DETEKTOR
ALTERNATIVA

"SUPER DC" PRIJEMNIK KOJI KORISTI PREDNOSTI SUPERHETERODINSKIH /
DC PRIJEMNIKA. PROJEKT YU1LM, YU1GD I YU1KM U REALIZACIJI

SINTETIZATORI 14
KVARCNI OŠILATORI 2.14 MHz
SINTETIZATORI 1 MAJU
KORAK 200 ÷ 500 kHz 362 MHz